

Weatherbeta 24 double glazed louvre window

- Linear Motor Control (LMC)
- Manual Control
- Fail Safe





Introduction

The development of energy conservation has prompted the need for a louvre range providing all the benefits of our Weatherbeta system while offering increased thermal protection.

Weatherbeta 24 has been developed over many years with our distributor in Germany (where our product is market leader) and is in use in a wide variety of ventilation applications.

Weatherbeta 24 is available for hand/pole or remote gear (e.g. Teleflex) operation together with options for electric motor and fail-safe actuator applications.

Materials

Frame and louvre blade sections are from extruded aluminium grade 6063T6 to BS 1474.. The standard handle is injection moulded acetal copolymer, black finish.

Finishes

Available in natural anodised, polyester powder coated (to RAL colour range) or black or bronze anodised (within agreed colour tolerances).

Glazing

24mm double glazed units available with a variety of glass types. Clear float units will be 4/16/4 (glass/cavity/glass).

Glass is supplied for site glazing. Tape gasket is fitted to the external side of the glazing profiles. Internal wedge gasket is supplied loose for site fitting by the glazier.

Security

The "smallpane" fully framed format of Weatherbeta 24 offers increased security for sensitive applications.

Operation

Standard handle is for hand/pole operation or drop rod.

Windows are available with 230v electric linear motors (LMC) or with fail safe 24 volt AC/DC actuators.

The maximum number of blades operable from one standard handle is five. Where LMC/fail safe windows are used the maximum number is 5 however, handles may be linked to provide a "single operator" position.

Fixing

Direct to structure (plaster finish) by fixing lugs. Timber/steel/fair faced structure by direct screw fix.

Construction

Surround frames are available with equal or unequal frame sections or with a single nib profile for patent glazing application.

A channel profile is also offered for application to window/curtain wall profiles.

Glazing bars are at 203mm (nominal) centres.

Sizes: Height

Windows are produced in a range of standard sizes with all blades opening. For sizes between 5mm and 15mm above or below a standard height, the top blade size will be adjusted and all blades will still open.

For all other sizes the number of opening blades is reduced and an extended fixed top blade is used e.g. unequal frame window 1240mm high. Size is more than 15mm both below a standard 6 blade height and above a standard 5 blade, therefore the top blade of the 5 blade unit will be extended and fixed closed, i.e. window is made with 4 No. opening blades and an extended, fixed top blade.

Length

The maximum length for a single window or panel is 1200mm. Windows are available in 1,2,3 or 4 panel units, within a maximum frame length of 2400mm, by using self mullion couplings. Self mullions are subject to exposure grade; see coupling details.

Coupling

Composite windows are provided by the use of mullion and transom sections.

Channel and single nib surround frames

Two channel frame options are available, 19 mm and 25 mm.

The single nib frame is available with a PVC channel profile providing a 6 mm thick nib.

Height sizes for these frames are as table below.

Frame Type	Relationship to unequal frame height sizes
Single nib	- 5 mm
Single nib with PVC	same
19 channel	same
25 channel	+ 12 mm

Standard blade sizes

Height Size		No. of Blades	No. of Handles	Handle Position		
Unequal Frame	Equal Frame			Single	Double	
					Lower	Upper
			Between	Between	Between	
475	449	2	1-2			
678	652	3	1-2			
881	855	4	2-3			
1085	1059	5	2-3			
1288	1262	6		1-2	4-5	
1491	1465	7		2-3	5-6	
1694	1668	8		2-3	6-7	
1897	1871	9		2-3	7-8	
2100	2074	10		2-3	7-8	

Fail safe windows

Description

Works assembled windows incorporating automatic opening ventilators providing a fail safe unit.

Offered as multiple panels only assembled with integral self mullions.

Fitted with 24 volt AC/DC electrically operated actuator(s). For day to day ventilation control the motor will power open / closed but on signal (cutting off electric power) the fail safe mechanism will open the window.

Application designed for high level situations where windows are linked into fail safe control system.

Handing

The mechanism for fail safe actuators may be positioned either on the left or the right hand side of the window or centrally.

Ventilation

Louvres are either closed or fully open giving approx. 53% free air space.

A 24 volt AC/DC actuator is available providing for variable ventilation.

Control panels

Control panels and related equipment must be obtained from a specialist supplier and be designed to satisfy control requirements.

Actuator specification

Frequency 50-60 Hz
Voltage 24V ac \pm 20%
24V dc \pm 10%
Current 0.375amps

Linear motor control LMC

Description

Works assembled windows incorporating 230 volt linear motor controlled ventilators providing a simple and effective control method for high level ventilation.

Offered in single or multiple panels the latter assembled with integral self mullion.

Application

Designed for high level situations.

Not for use in modulating mode where constant adjustment occurs.

Handing

The mechanism for linear motor controlled ventilators may be positioned either on the left or the right hand side of the window or centrally.

Ventilation

Adjustable to any required degree of ventilation from nil to approx. 53% free air space. Panels having more than five blades are linked together to allow control from one linear motor.

Motor Specification

Frequency 50 Hz
Voltage 230 V.AC
(single ph)
Current 0.60 amps
Pull 15-20 kg

Installation

Fixed directly into Weatherbeta louvre windows with internal wiring. Flying leads terminate at head of window.

Electrical equipment

The linear motor is supplied fitted to the window. All other electrical control equipment must be obtained from a specialist supplier. The control switch must spring return to 'off'. Multiple motors may be connected parallel to one switch. The motor is protected by a thermal cut-out which if activated will automatically reset after 25 - 30 minutes.

Electrical installation

The electrical installation must only be carried out by a qualified electrical contractor in compliance with current safety regulations of the country of use. In the UK this is the IEE Wiring Regulations 16th Edition 'Requirements for Electrical Installations' BS7671: 1992 as amended.'

This covers specific requirements for the earth bonding of metal windows.

Typical panel arrangements



4-5 blade units

Maximum 10 blades from one actuator

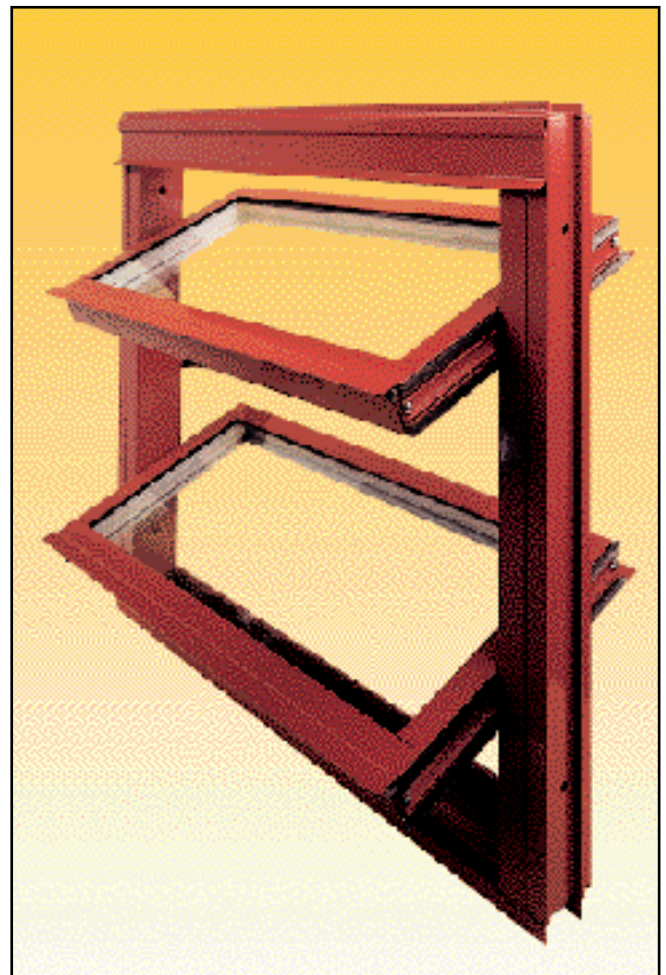

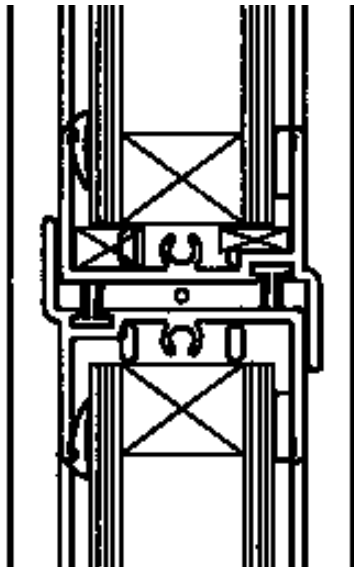
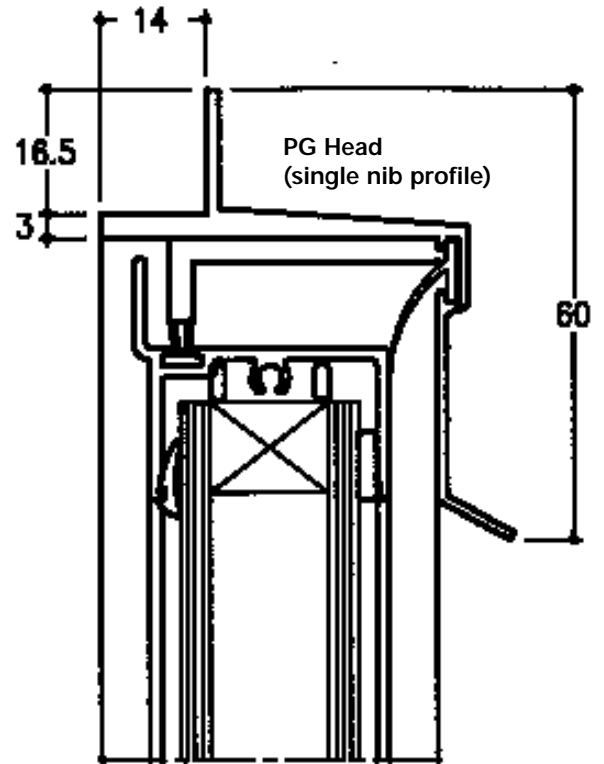
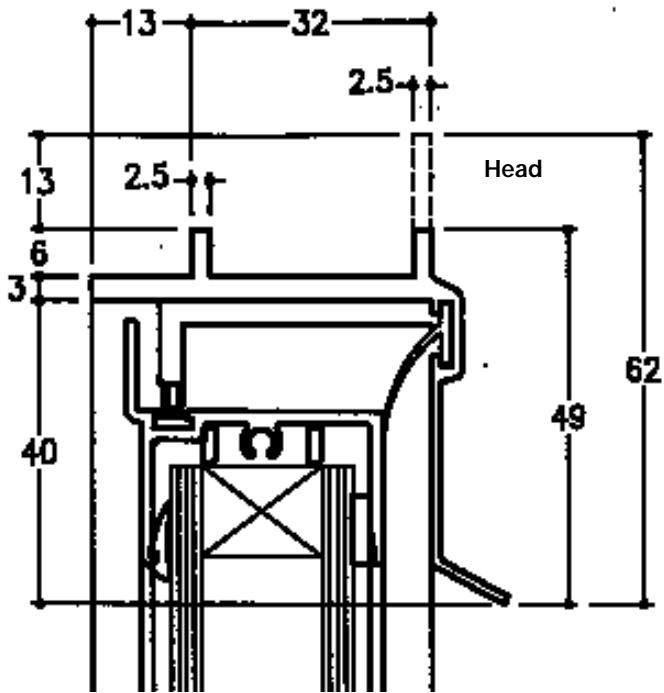

Horizontal rail

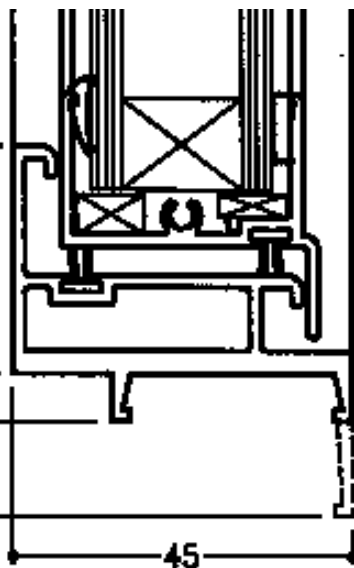

Cill

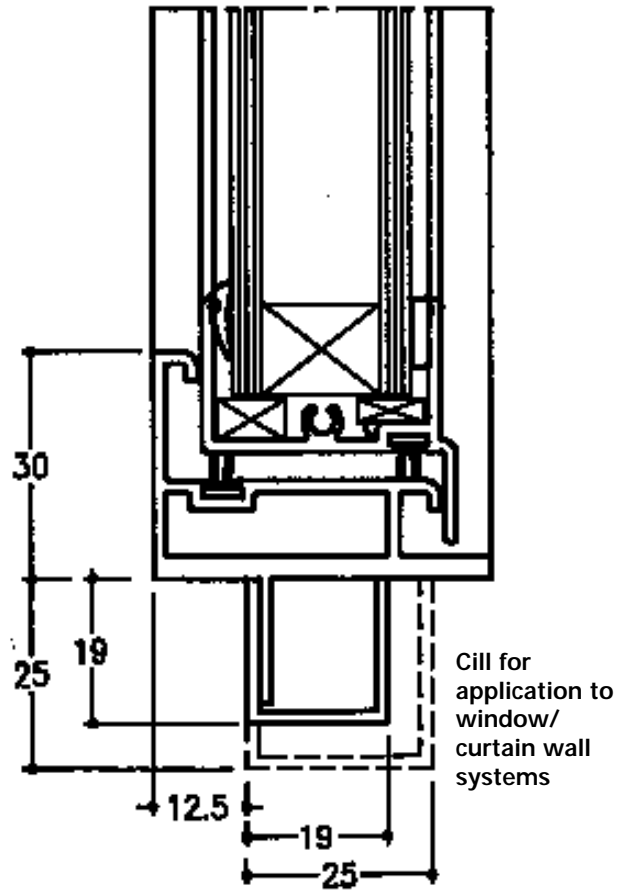

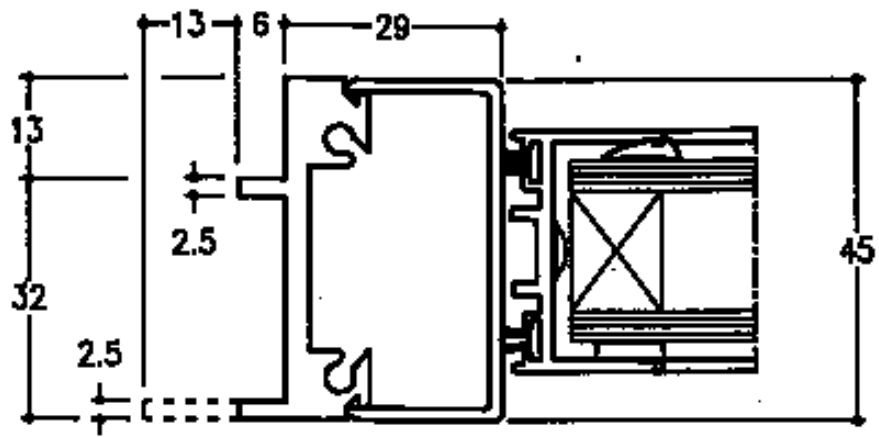

Jamb

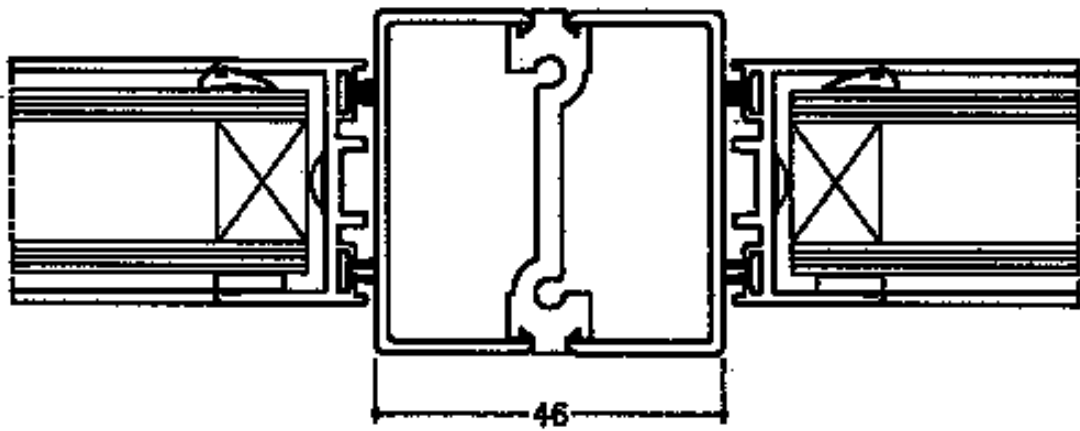

Self mullion

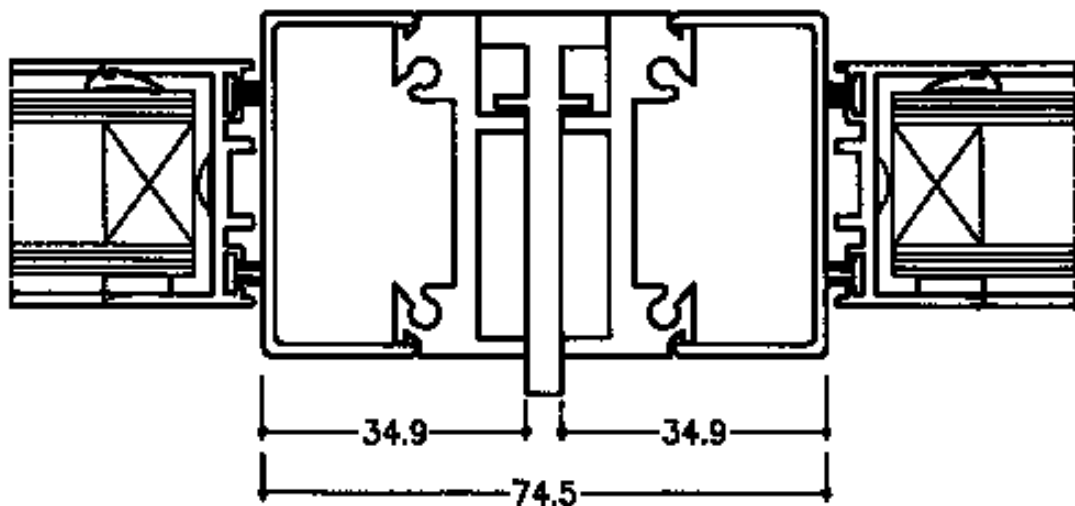

Coupling

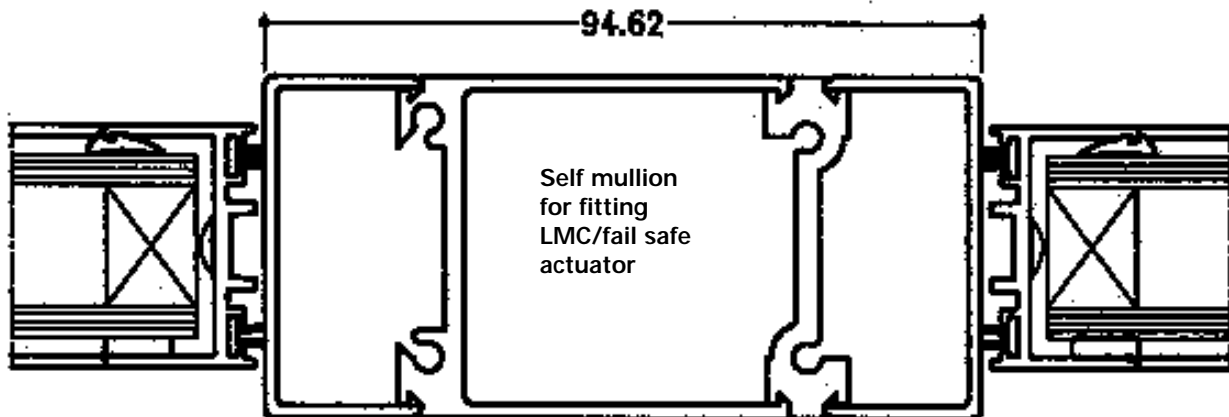
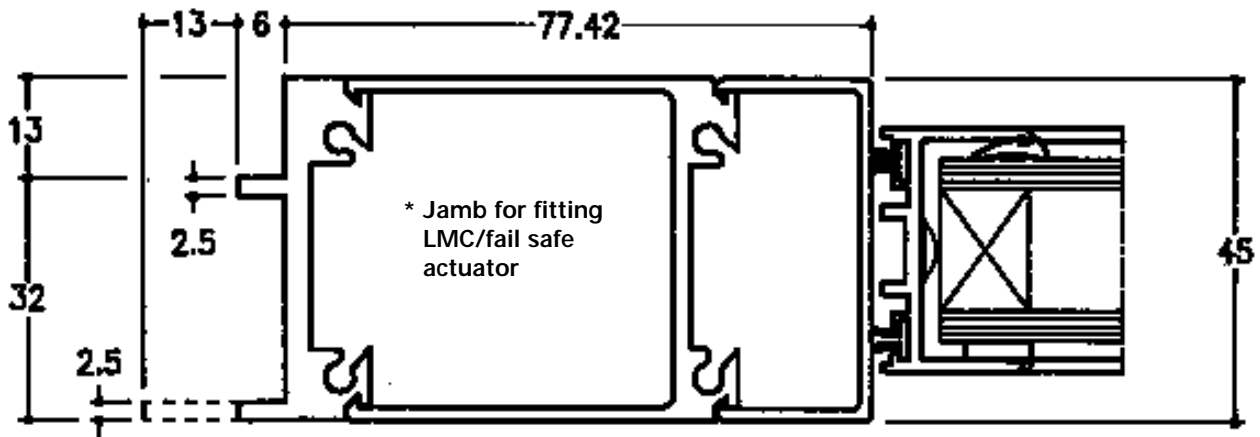

* on fail safe windows the jamb detail needs consideration as the actuator projects on the inside to a line level with the unequal frame profile.

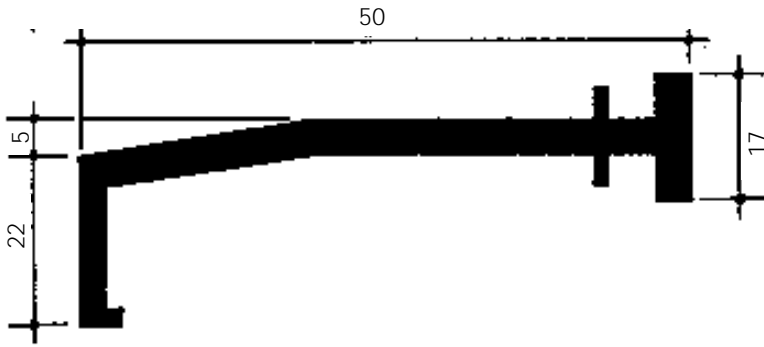

Coupling transom ET2

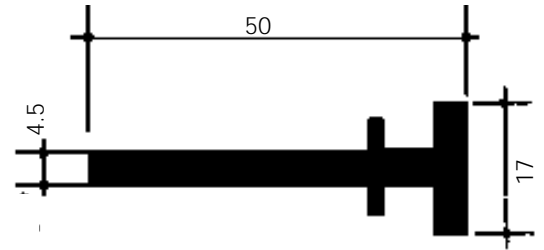

Coupling mullion EM1

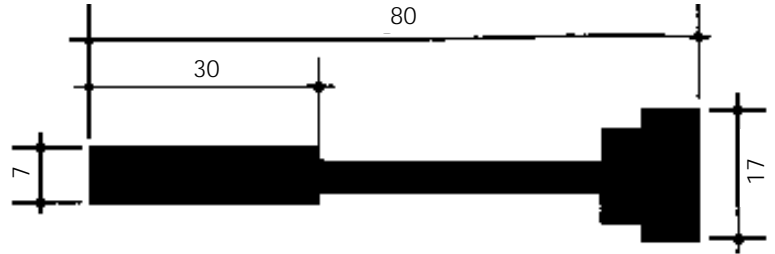

Coupling mullion EM2

MULLION CHART

Wind Load	Mullion Type	Max Panel Length	Mullion Height
up to 1500pa (sheltered)	45mm self mullion	1200	1600
up to 1900pa (moderate)	45mm self mullion	900	1500
	80mm self mullion/LMC	1000	1700
	self mullion	1200	1500
up to 2300pa (severe)	80mm self mullion/LMC	1200	1500
	self mullion	1000	1700
up to 1900pa	EM1	1200	1500
		1200	1700
	EM2	1100	1900
		950	2000
up to 2300pa	EM2	1200	1500
		1100	1800

UNIT PARAMETERS

Exposure	Max. No. of Blades
Sheltered	10
Moderate	9
Severe	8

TRANSOM CHART

Wind Load	Transom	Max Panel Length	Transom Centres
up to 1900pa	ET2	1800 double panel	1200
up to 2300pa	ET2	1200	1700
	EM1	single panel	

Ruskin Air Management Ltd

a BS EN ISO 9000 registered company

The statements made in this brochure or by our representatives in consequence of any enquiries arising out of this document are given for information purposes only. They are not intended to have any legal effect and the company is not to be regarded as bound thereby. The company will only accept obligations which are expressly negotiated for and agreed and incorporated into a written agreement made with its customers.

Due to a policy of continuous product development the specification and details contained herein are subject to alteration without prior notice.

Stourbridge Road
Bridgnorth
Shropshire WV15 5BB

Telephone +44 (0)1746 761921
Facsimile +44 (0)1746 766450

Website www.naco.co.uk
E-mail sales@naco.co.uk

