

External Metal Louvres

- Storm Louvres
- Drainable Louvres
- Standard Louvres
- Penthouse Louvres
- Doors
- Screens
- Movable Blade
- Slimtype
- Polycarbonate



	Page
Louvre selection guide	2
Performance data	3
Pressure loss / sizing data	4
50 standard series	5
75 standard series	6
100 standard series	7
Screen louvres	8
75p series	9
Storm louvres	10 – 12
Movable blade louvres	13
Louvred doors & access panels	14 – 15
PH series penthouse louvres	16 – 18
75 Polycarbonate blade louvre	19
Slimtype louvre	20
Trickle louvre	21
Project photographs	22
ST series sandtrap louvres	23
General coupling details	24
Typical fixing arrangements	25
Product range	26
Survey and installation service	27



Type

Use

**Standard (non drainable) louvres.
Horizontal blade**

Use in sheltered areas and where water entry will not damage the building fabric. Also used for screen walling (with blanking plates fitted) and plantroom screens.



**75P (drainable) louvres
Horizontal blade**

Provides improved water protection over standard louvres. Use in more exposed areas and where increased protection from wind driven rain is required.

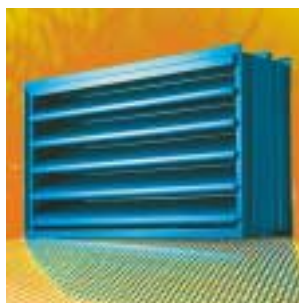

**SLH-S Storm louvre
Horizontal blade**

A superior design providing a very high level of water protection unmatched by other single bank systems.

**SLH Storm louvre
Horizontal blade
Sight proof**

For use in any location where restricted wind driven rain penetration is required.

**SLV Storm louvre
Vertical blade
Sight proof**

Top of the range performance louvre for use where 'dry room' conditions are required. Unmatched by any competitive design, offering superb aerodynamic and water rejection properties.



**SLH-SD Horizontal blade
Double bank**

Probably the best louvre available of its kind. Combining excellent water rejection with good aerodynamics. Use in locations where water entry must be the minimum possible.



75 Polycarbonate blade

For areas where increased daylight combined with ventilation are required; eg. stairs, corridor areas etc.

Slimtype & Trickle

Small format simple ventilation systems for window / door applications where water ingress is acceptable.



The following graph details louvre efficiency comparisons (water rejection) for our storm louvres

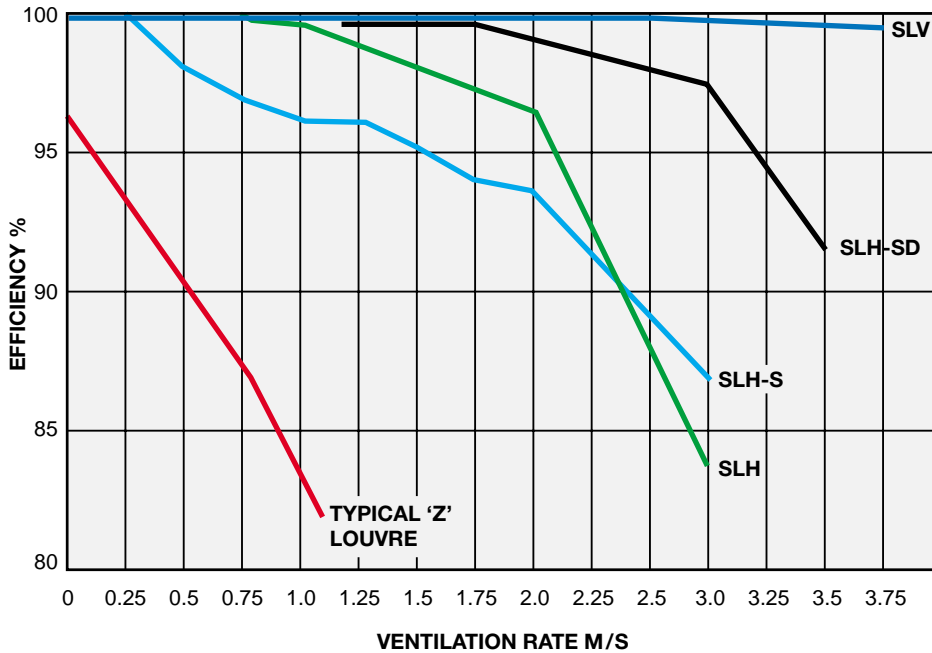

Weather louvres are classified by their ability to reject simulated rain.

Classifications are as follows:-
The water effectiveness is denoted by:

Class	Effectiveness
A	1 to 0.99
B	0.989 to 0.95
C	0.949 to 0.80
D	below 0.8

ie. 0.99 effectiveness 99% water repellent efficiency.

The aerodynamic effectiveness is:

Class	Discharge / entry Loss coefficient
1	0.4 and above
2	0.3 to 0.399
3	0.2 to 0.299
4	0.199 and below

The water penetration class letter should precede the coefficient of discharge class letter followed by the limiting core velocity, eg.

A1 up to 3.5 m/s

Test Classification

Water Class	Cd Class	Core Velocity
SLV		
A	1	Up to 3.5 m/s
SLH		
A	3	Up to 1.0 m/s
B	3	1.0 to 2.0 m/s
C	3	2.0 to 3.0 m/s
SLH-S		
B	2	Up to 1.5 m/s
C	2	1.5 to 2.9 m/s
SLH-SD		
A	3	Up to 2.0 m/s
B	3	2.0 to 3.0 m/s
C	3	3.0 to 3.5 m/s
75P		
B	3	Up to 0.5 m/s
C	3	0.5 to 2.0 m/s
75 Polycarbonate		
B	3	Up to 0.5 m/s
C	3	0.5 to 1.0 m/s
Standard series 50/75/100		
C	3	Up to 1.5 m/s

Classification from design tests carried out by BSRIA to the HEVAC technical specification now developed and published as BS EN ISO 13030.

Materials and finishes

All louvres within the Naco range are normally manufactured from aluminium extrusions. Flashings where required will be formed from pressed aluminium sheet.

Powder coated

Louvre assemblies and flashings can be powder coated matt polyester to BS and RAL colours.

Anodising

Louvres and flashings may be natural or colour anodised within commercial colour tolerances which will be agreed for each project.

Mill finish

Louvres and flashings may be supplied in mill finish and while the integrity of the material is unaffected, the visual appearance will be impaired due to the natural oxidisation process which will occur on mill finish aluminium, therefore painting is recommended to enhance the finished product.

General construction

Louvres are produced in factory assembled panels for coupling into final assemblies on site. The normal maximum panel size is approximately 1.5m x 2.5m and horizontal or vertical louvre assemblies will normally be supplied within these limitations. Larger shaped or circular louvre assemblies will be manufactured in panel sizes. SLV & SLH panels are produced in 2m² units for coupling on site. Larger louvre assemblies may require intermediate steel support rails which would normally be provided by the general contractor in consultation with our design office.

Pressure loss / louvre sizing data



Pressure loss

Pressure loss occurs when a louvre is inserted into an opening and may be found from:

$$Pa = \left(\frac{\sqrt{\frac{1}{2} \rho \times V^2}}{Cd} \right)^2$$

ρ = Air density (1.2 Kg/m³)
 V = Face velocity i.e.:

$$\frac{\text{Volume (m}^3\text{/s)}}{\text{Louvre core area (m}^2\text{)}}$$

or

$$V = \frac{\sqrt{Pa \times Cd^2}}{\sqrt{\frac{1}{2} \rho}}$$

Cd is louvre coefficient of discharge.

Cd and Ce figures can, for all practical purposes, be taken as the same.

50 standard	0.224
75 standard	0.229
100 standard	0.207
75p	0.275
SLH-S	0.345
SLH-SD	0.262
SLH	0.255
SLV	0.419
75 polycarbonate	0.212
50S - 65%	0.328

Example

Size a 100 series louvre with bird wire guard which is capable of handling 15m³/s in intake mode with a pressure drop of not more than 25Pa.

1.

From velocity formula:

$$V = \frac{\sqrt{Pa \times Cd^2}}{\sqrt{\frac{1}{2} \rho}}$$

$$V = \frac{\sqrt{25 \times 0.207^2}}{0.6}$$

Velocity for a pressure drop of 25 Pa is 1.34 m/s

2.

$$\frac{\text{Volume}}{\text{Velocity}} = \text{Area}$$

$$\frac{15}{1.34} = 11.2\text{m}^2$$

Therefore a louvre area of 11.2m² is required:

Penthouse louvres should be sized as 4 panels of equal height which, when added together, will give the required figure.

Free area

This is the minimum measured area of each opening through which air can pass.

$$\text{Free area} = \frac{\text{air volume m}^3\text{/s}}{\text{air velocity m/s}}$$

$$\text{Louvre area} = \frac{\text{Louvre free area m}^2}{\text{louvre free area\%}}$$

Example:

100 series louvre
 (43% free area)
 Volume 15 m³/s
 Velocity 3.12 m/s

$$\text{Free area m}^2 = \frac{15}{3.12} = 4.81\text{m}^2$$

Therefore:

$$\text{louvre area} = \frac{4.81}{0.43} = 11.2\text{m}^2$$

Pressure loss

Face velocity m/s	1.50	1.75	2.00	2.25	2.50	2.75	3.00
Pa - 50 standard series	26	36	48	60	75	90	108
Pa - 75 standard series	26	35	48	60	72	87	103
Pa - 100 standard series	32	43	56	71	88	106	126
Pa - 75p	18	25	33	41	51	62	74
Pa - SLH-S	13	17	22	29	34	41	49
Pa - SLH-SD	21	29	38	49	60	71	85
Pa - SLH	24	32	41	53	65	80	92
Pa - SLV	9	13	15	19	24	29	34
Pa - 75 polycarbonate	30	41	53	68	83	101	120
Pa - 50S - 65%	13	17	22	28	35	42	50

Note:

All figures are for a louvre fitted with bird wire guard.
 All figures shown to nearest rounded value.
 Face velocity is total air volume ÷ louvre core area [use these figures in calculation].

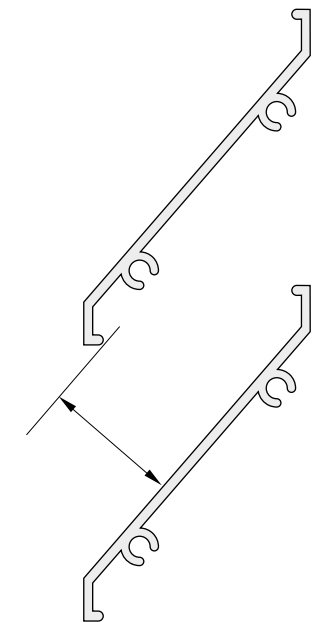

Free areas stated in this brochure are core areas based on 1m² louvres. Smaller sizes can reduce free area.

Fixed blade external louvres with 50 mm blade spacing.
Particularly suitable for smaller applications where a balanced appearance is required. Continuous line standard construction.

Specification

Materials

Extruded aluminium grade ENAW 6063T6 to BSEN 755 -1 and -9.

Frame construction

Screw joints as standard.

Corner blades

Mitred and welded.

Finishes

Extruded aluminium (mill finish).

Polyester powder – coated to BS6496.

Anodised to BS3987.

Bird wire guard

Fitted as standard, 18g expanded aluminium.

Insect screen

If specified, 23g expanded aluminium.

Blanking plates

If specified – 18g aluminium.

Free area

The core area provides approximately 50% free area.

Stiffener bars

Rear mounted stiffener bars are fitted as standard to louvres over 0.9m in width.

Stiffener bars do not interrupt the external continuous line appearance of louvre blades. Louvre blades are secured to stiffener bars via aluminium support clips.

Mullions

Units manufactured in two or more panels have reverse concealed mullions which project 24 mm beyond the rear of the frame.

Frame types

A or AC frames are available (and may be combined if required, eg A head, AC cill) together with AC channel frame for glazing applications; glazing thickness 20 or 25mm.

Fixing conditions

Generally as pages 24 and 25.

Note

Where height dimension is not completely divisible by blade centres, the head blade will comprise a formed section.

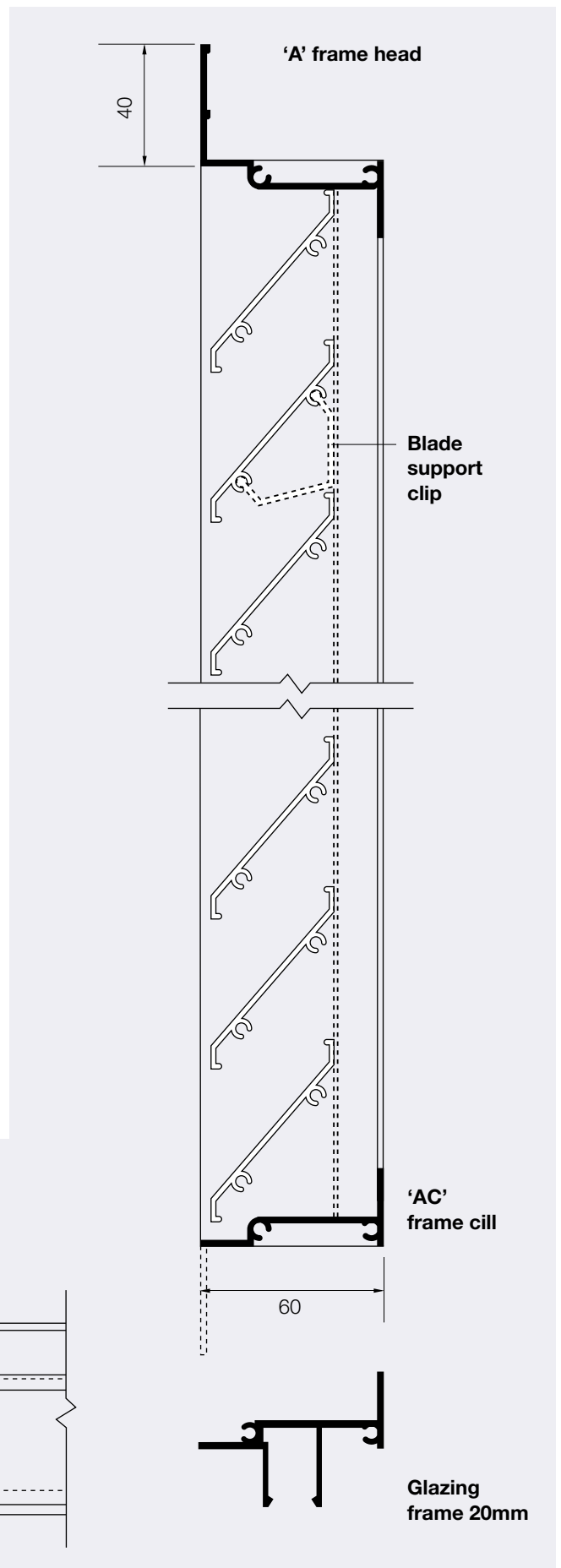

Glazing frame 25mm

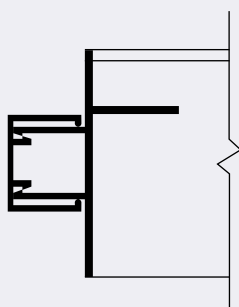

SCALE 1:2

'AC' frame jamb

'A' frame jamb shown dotted

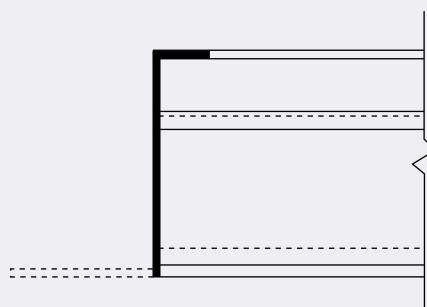

'AC' frame cill

Glazing frame 20mm

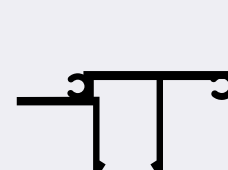

Fixed blade external louvres with 75mm blade spacing. Suitable for a wide range of louvre assemblies where a 'brick course' line is required. Continuous line standard construction.

Specification

Materials

Extruded aluminium grade ENAW 6063T6 to BSEN 755 -1 and -9

Blades

1.6mm extruded aluminium.

Corner frames

Screw or welded joints depending on size and construction.

Corner blades

Mitred and welded.

Finishes

Extruded Aluminium (Mill finish). Polyester powder – coated to BS6496. Anodised to BS3987

Bird wire guard

Fitted as standard, 18g expanded aluminium.

Insect screen

If specified, 23g expanded aluminium.

Blanking plates

If specified – 18g aluminium.

Free area

The face core area provides approximately 47% free area.

Stiffener bars

Rear mounted stiffener bars are fitted as standard to all louvres over 1.2m in width.

Stiffener bars do not interrupt the external continuous line appearance of louvre blades. Louvre blades are secured to stiffener bars via aluminium support clips.

Mullions

Units manufactured in two or more panels have reverse concealed mullions which project 45mm beyond the rear of the frame.

Frame types

A or AC frames are available (and may be combined if required, eg. A head, AC cill) together with AC channel frame for glazing applications glazing thickness 25mm.

Fixing conditions

Generally as pages 24 and 25.

Note

Where height dimension is not completely divisible by blade centres, the head blade will comprise a formed section.

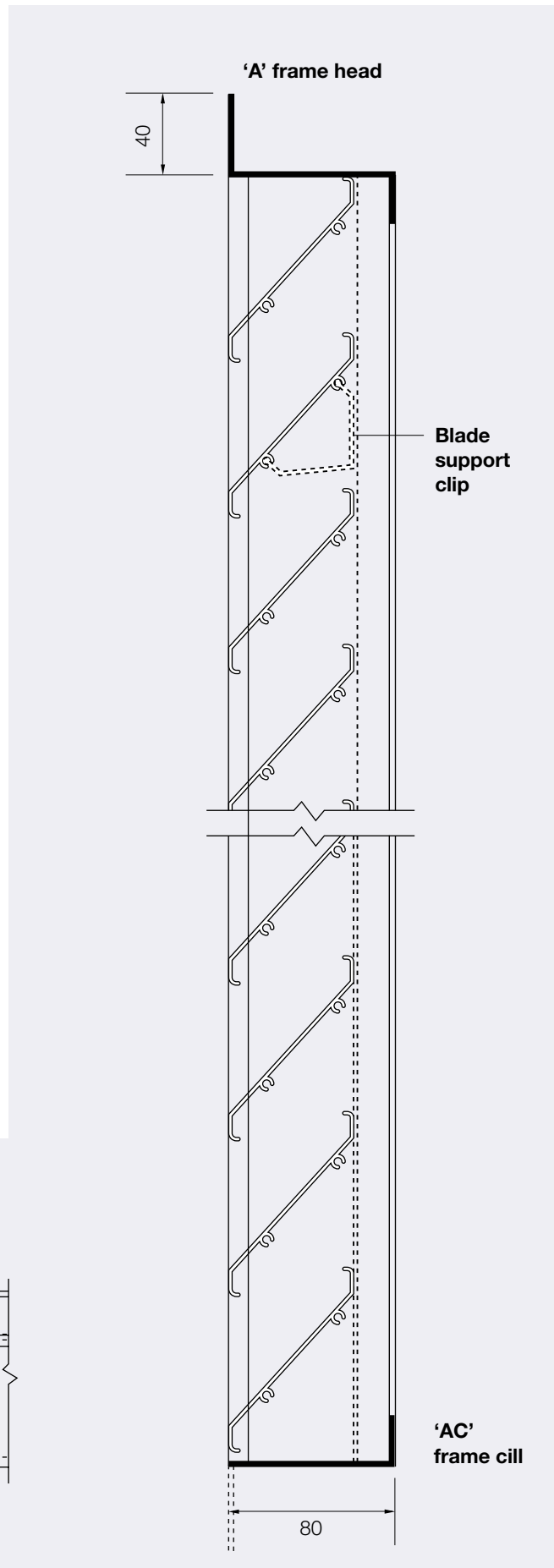

'AC' channel frame jamb

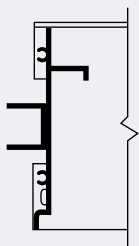

'AC' frame jamb

'A' frame jamb shown dotted

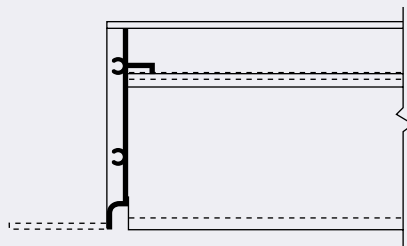

SCALE 1:3

Fixed blade external louvres with 100 mm blade spacing. Suitable for larger louvre assemblies where greater definition is required. Continuous line is standard.

Specification

Materials

Extruded aluminium grade ENAW 6063T6 to BSEN 755 -1 and -9.

Blades

2.0mm extruded aluminium.

Corner frames

Screw or welded joints depending on size and construction.

Corner blades

Mitred and welded.

Finishes

Extruded Aluminium (Mill finish). Polyester powder – coated to BS6496. Anodised to BS3987.

Bird wire guard

Fitted as standard, 18g expanded aluminium.

Insect screen

If specified, 23g expanded aluminium.

Blanking plates

If specified – 18g aluminium.

Free area

The face core area provides approximately 43% free area.

Stiffener bars

Rear mounted stiffener bars are fitted as standard to all louvres over 1.50m in width.

Stiffener bars do not interrupt the external continuous line appearance of louvre blades. Louvre blades are secured to stiffener bars via aluminium support clips.

Mullions

Units manufactured in two or more panels have reverse concealed mullions which project 10mm or 35mm beyond the rear of the frame.

Frame types

A or AC frames are available (and may be combined if required, eg A head, AC cill) together with AC channel frame for glazing applications glazing thickness 25mm.

Fixing conditions

Generally as pages 24 and 25.

Note

Where height dimension is not completely divisible by blade centres, the head blade will comprise a formed section.

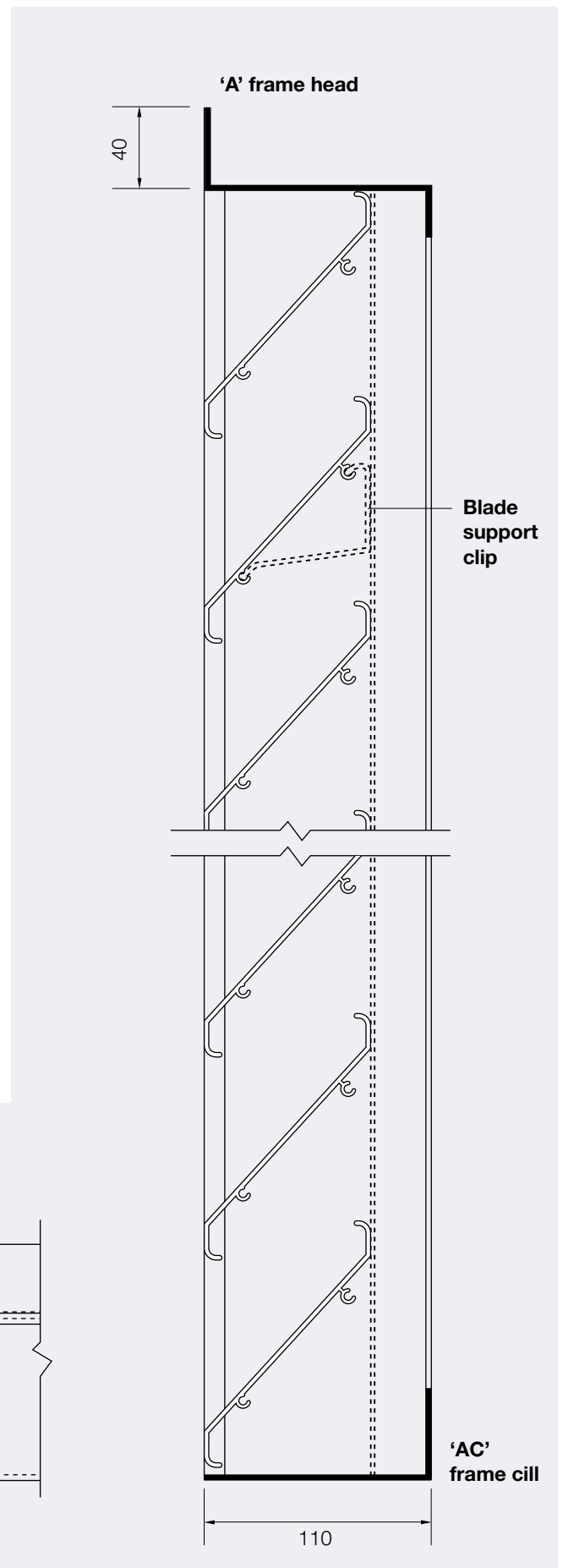

'AC' channel frame jamb

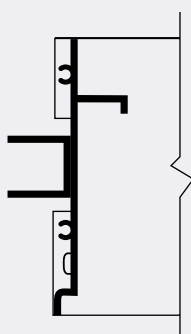

'AC' frame jamb
'A' frame jamb shown dotted

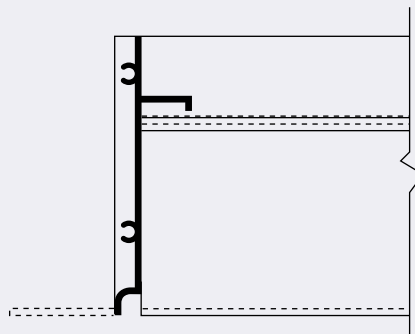

SCALE 1:3

Where louvre assemblies are to be utilised for screening purposes rather than as conventional weather louvres, they are manufactured from 50,75 or 100 standard series blade profiles, dependent on screen size, but with revised pitch centres.

Blade type	Pitch centres
50	59
75	88
100	118

Conventional border frames will not be supplied at head and cill unless required by the particular design.

Vertical screen louvres will require a steelwork support system provided by the general contractor in discussion with our design office. If required steelwork can be provided as part of our overall supply and installation package.

Vertical screen louvres may be used on external walls where a decorative rather than functional requirement is needed.

Inverted blade

Manufactured from 50, 75 or 100 standard series blade profiles with blade spacings as above. For applications where a non vision screen is required (viewed from below), it may be advisable to consider the use of inverted blade louvres to maintain the 'screen' appearance – inverted blades should only be used in 'open' areas as they do not provide weather protection.

Vertical screen

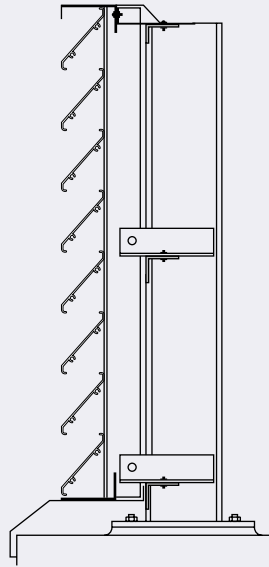

Lean back screen - conventional blade

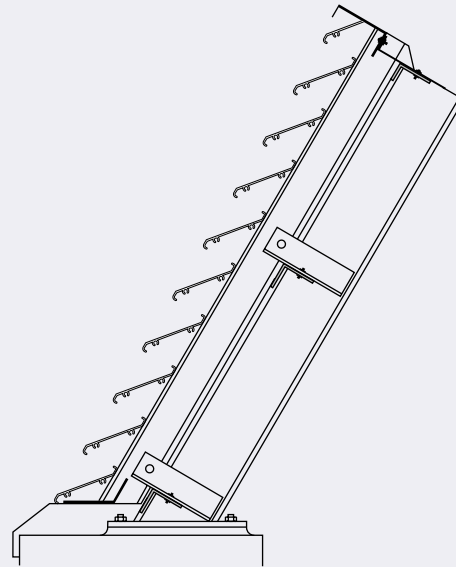

Lean back screen - inverted blade

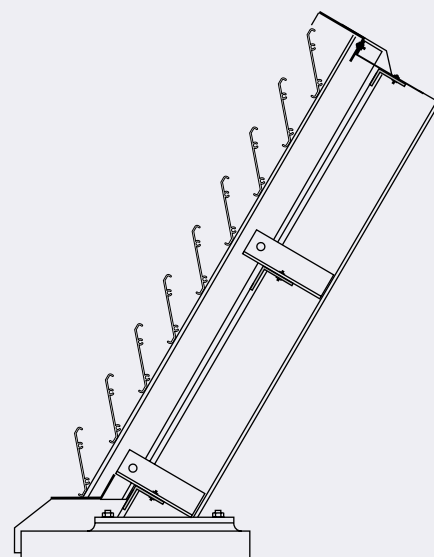

Pitch centres

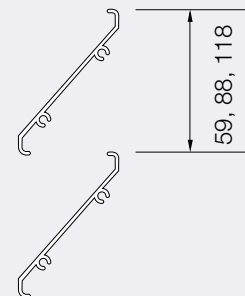

Fixed blade drainable louvres providing improved weather protection over standard series.

Specification

Materials

Extruded aluminium grade ENAW 6063T6 to BSEN 755 -1 and -9.

Blades

1.6mm extruded aluminium.

Corner frames

Screw or welded joints depending on size and construction.

Corner blades

Mitred and welded.

Finishes

Extruded aluminium (mill finish). Polyester powder – coated to BS6496. Anodised to BS3987.

Bird wire guard

Fitted as standard, 18g expanded aluminium.

Insect screen

If specified, 23g expanded aluminium.

Blanking plates

If specified – 18g aluminium.

Free area

The face core area provides approximately 50% free area.

Stiffener bars

Rear mounted stiffener bars are fitted as standard to all louvres over 1.2m in width.

Stiffener bars do not interrupt the external continuous line appearance of louvre blades. Louvre blades are secured to stiffener bars via aluminium support clips.

Mullions

Units manufactured in two or more panels have reverse concealed mullions which project 10mm or 35mm beyond the rear of the frame.

Frame types

A or AC frames are available (and may be combined if required, eg A head, AC cill) together with AC channel frame for glazing applications glazing thickness 25mm.

Fixing conditions

Generally as pages 24 and 25.

Note

Where height dimension is not completely divisible by blade centres, the head blade will comprise a formed section.

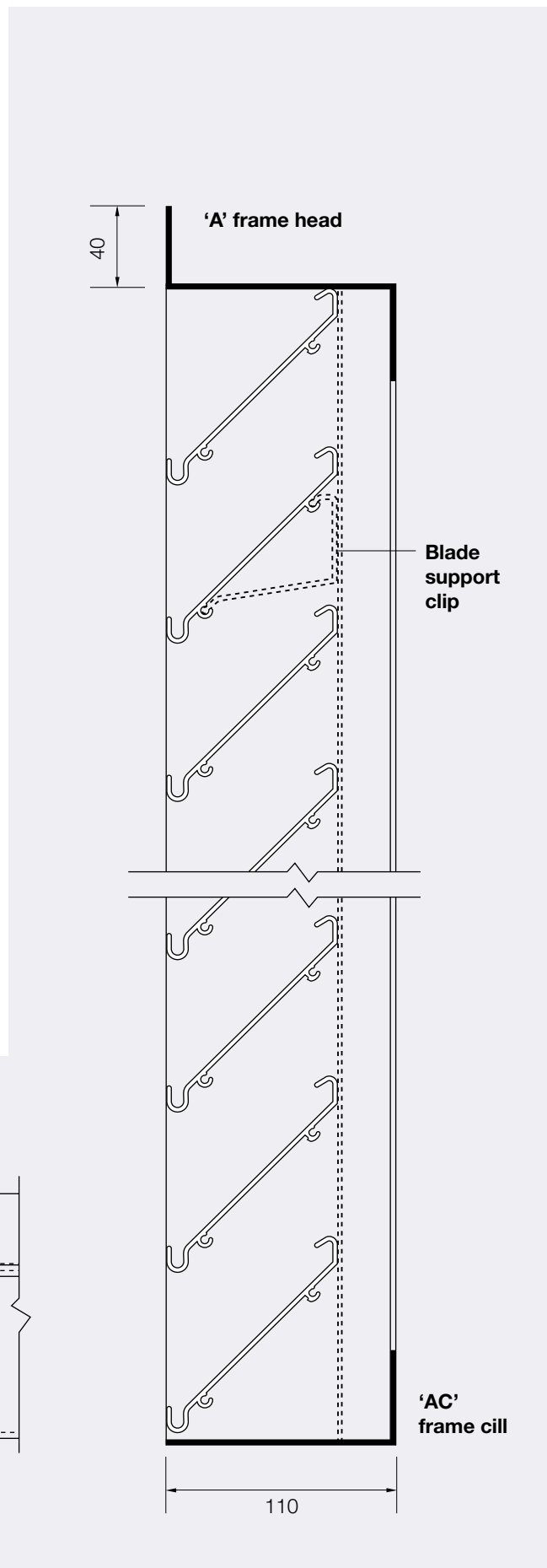

'AC' channel frame jamb

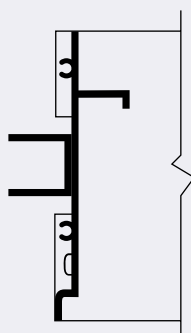

'AC' frame jamb
'A' frame jamb shown dotted

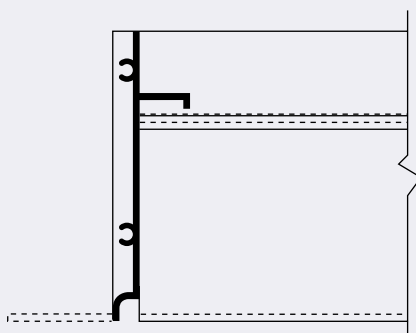

SCALE 1:3

Storm Louvres



Tests carried out by BSRIA to the HEVAC technical specification now developed and published as BS EN 13030.

Vertical blade SLV provides the top classification for both aerodynamic and water rejection effectiveness.

So smaller areas of louvre are required or larger air volumes can be handled without problem.

Horizontal blade louvres offer 3 styles to cater for most conditions including a remarkably efficient single blade design and a very good double bank system.

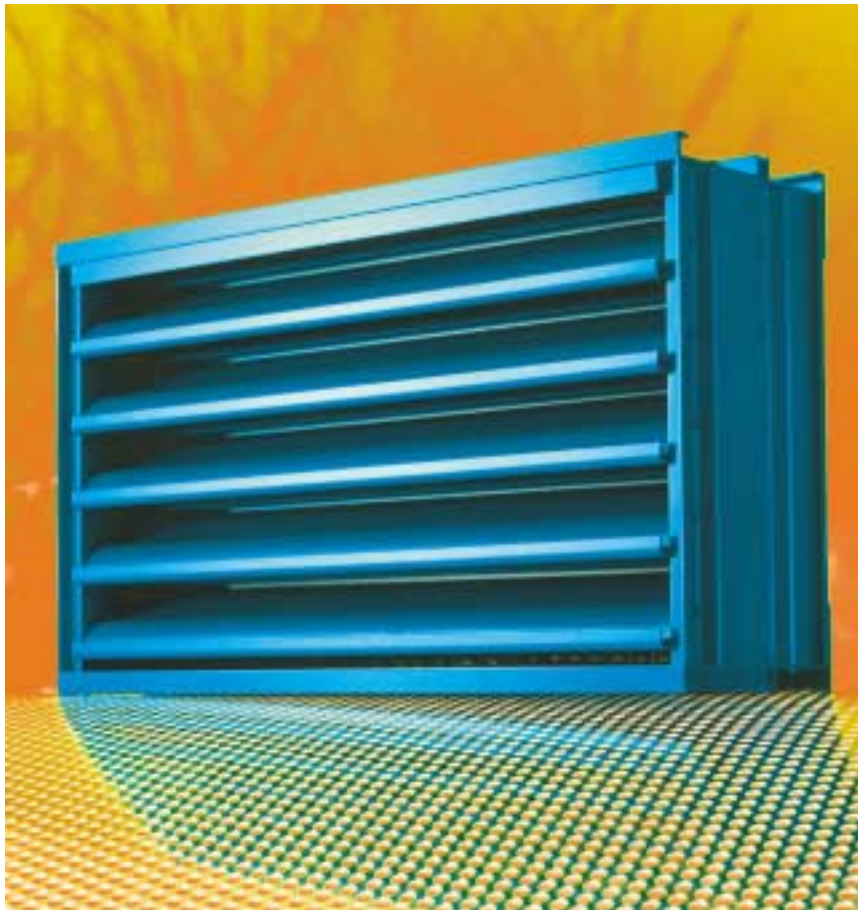

Storm louvre Vertical blade - SLV



Introduction

A new design of storm louvre bringing advanced technology to metal louvre systems.

Vertical blade design which provides exceptional resistance to wind driven rain.

Ideal for areas where rain is required to be kept out of the building.

The remarkable performance provided by the SLV louvre is due to the carefully researched blade profile – this allows air to pass, but diverts and captures water particles and prevents water ingress even under the most extreme conditions of test.

A major benefit for our customers is cost saving: no longer is it necessary to have double or triple bank systems to prevent water ingress – it can now be achieved in a single bank, single frame style, and with better results.

The vertical blade SLV provides a dramatic alternative to the 'normal' concept of louvre systems. So the designer now has the freedom to exploit vertical dimensions within ventilation systems.

The SLV design provides 'dry room' conditions so no longer is it necessary to accept water passing through louvre systems.

Developed in the USA by our associate company Ruskin, this blade design meets the highest standards of the AMCA Wind Driven Rain Penetration Test and European Standard for weather louvre performance.

Specification

Materials

Extruded aluminium grade ENAW 6063T6 to BSEN 755 -1 and -9.

Blades – SLV

2.0 mm extruded aluminium.

Corner frames

Screw or welded joints depending on size and construction.

Finishes

Extruded Aluminium (Mill finish). Polyester powder – coated to BS6496. Anodised to BS3987.

Bird wire guard (Mill finish)

Fitted as standard, 18g expanded aluminium.

Insect screen

If specified, 23g expanded aluminium.

Blanking plates

If specified – 18g aluminium.

Free area

The face core area provides approximately 58% free area.

Coupling – SLV

Can be coupled vertically or horizontally to form large areas of louvre. Continuous line horizontal option available.

Frame types

Slim equal edge profile frames are available together with channel frame for glazing applications – glazing thickness 25mm.

Fixing conditions

Generally as shown.

Note

SLV louvres are only available in square or rectangular shapes.

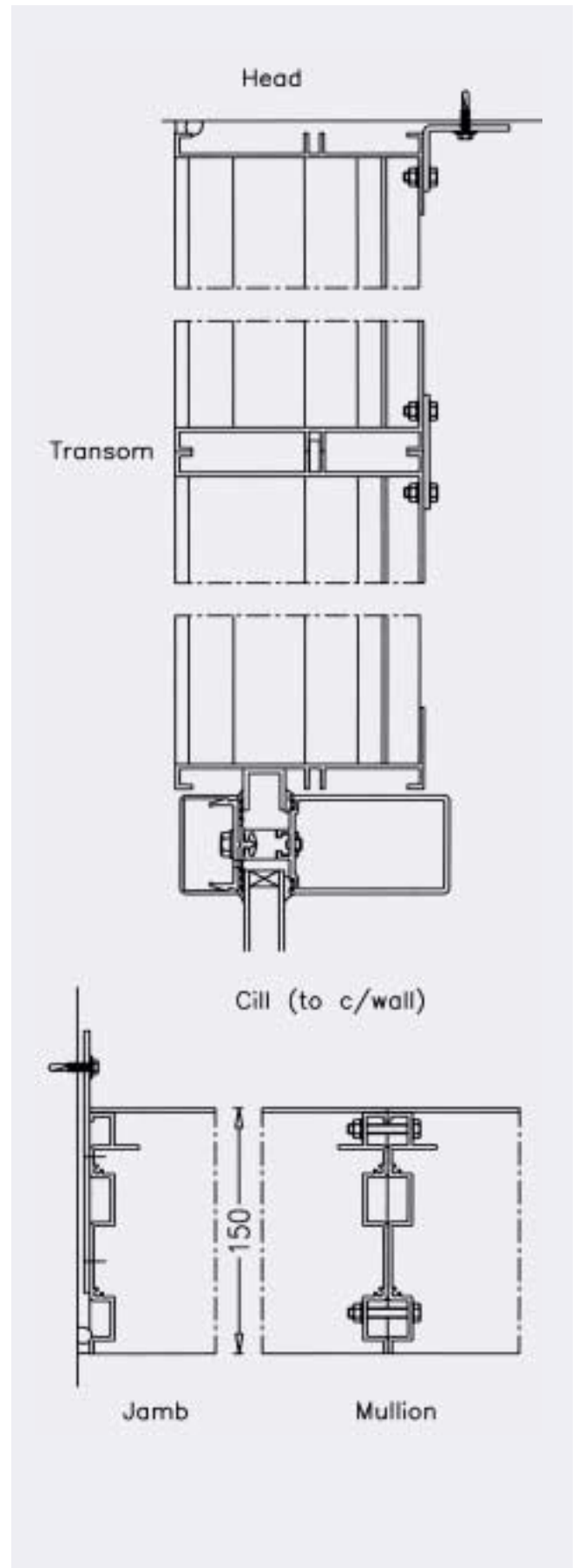

Storm louvre

Horizontal blade

SLH / SLH-S / SLH-SD



Introduction

The prime function of a louvre system is to provide a barrier to water ingress while allowing good air flow.

Our suite of SLH louvres offers a choice of high performance products to meet the demands of modern buildings.

SLH

This is a sight proof design providing excellent water rejection. Blade profile incorporates an anti-cascade feature on the front face, a water separation profile at mid point together with internal collection and drain systems.

SLH-S

A high performance single blade design with an external appearance match with the SLH louvre.

SLH-S assemblies can be used on their own or may be combined with SLH schemes (for instance, where non active louvres are required to be blanked off).

SLH-S blades can be fitted into doors to provide matching appearance with louvre assemblies.

SLH - SD

Double bank louvre system providing a high level of water rejection.

Normal use would be in conjunction with SLH-S units where improved water resistance is required for specific areas.

Specification

Materials

Extruded aluminium grade ENAW 6063T6 to BSEN 755 -1 and -9.

Blades

1.7mm extruded aluminium.

Corner frames

Screw or welded joints depending on size and construction.

Finishes

Extruded Aluminium (Mill finish). Polyester powder – coated to BS6496. Anodised to BS3987.

Bird wire guard

Mill finish fitted as standard, (18g expanded aluminium) to SLH, SLH-S will have 18g expanded aluminium to match louvre finish.

Insect screen

If specified, 23g expanded aluminium.

Blanking plates

If specified – 18g aluminium.

Free area

The face core area provides approximately 53% free area.

Coupling

Can be coupled vertically or horizontally to form large areas of louvre. Continuous line is standard.

Frame - SLH

Slim equal edge profile frames are available together with channel frame for glazing applications -glazing thickness 25mm.

Frame - SLH-S & SLH-SD

A or AC frames are available together with channel frame for glazing applications.

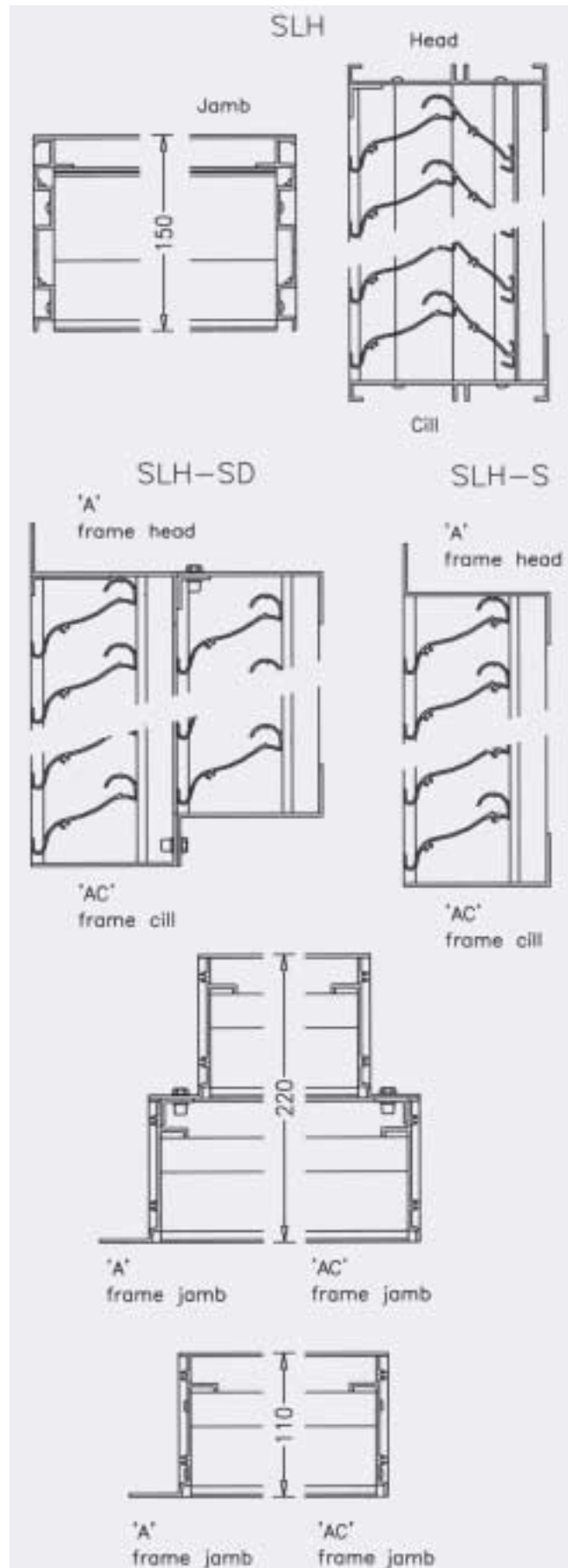

MBL series Movable blade louvres



Movable blade external louvres with 100mm blade spacing. Blades are parallel linked and pivot in phosphor-bronze self lubricating bushes, with a choice of actuating mechanisms.

Designed for use where ventilation to outside air is required but must be regulated e.g. store rooms and plant rooms.

Specification

Materials

Extruded aluminium grade ENAW 6063T6 to BSEN 755 -1 and -9.

Blades

2.0mm extruded aluminium.

Border

Front flange type as standard.

Types

Single panel

Maximum 1500w x 2000h with one actuator / vertical link rod.

Double panel

Manufactured in single frame construction with self mullion. One actuator / vertical link rod per panel.

Multi panel

Horizontal runs of MBL panels are supplied by coupling single and/or double panel units together, while maintaining a consistent external appearance.

Vertically banked panels can be provided utilising single or double panel types. Supporting steelwork is usually required for these applications.

Bird wire guard

If specified.

Insect screen

If specified.

Actuation standard

Manual or electric actuator: The electric actuator will be fitted so that with power off the louvres will open.

Non standard

Louvre may be prepared for connection to a remote Teleflex type operator or pneumatic actuator (supplied by others).

Type 100MBL

Dim	Description	Size mm
a	Front flange	40
b	Fitting clearance	7.5

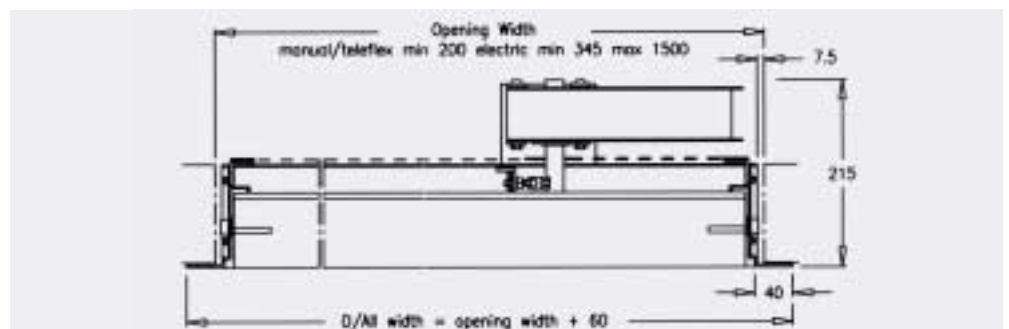
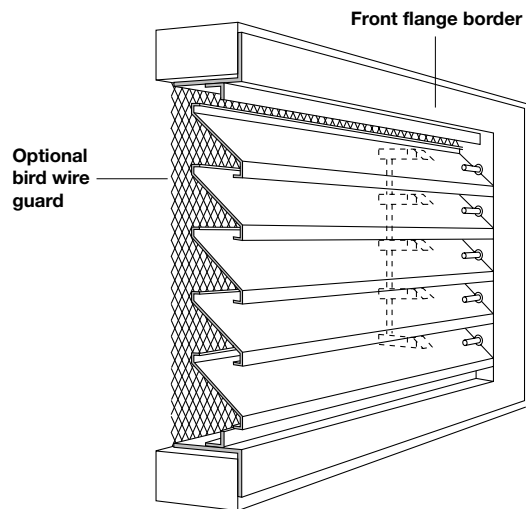

Panel coupling detail

Self mullion detail

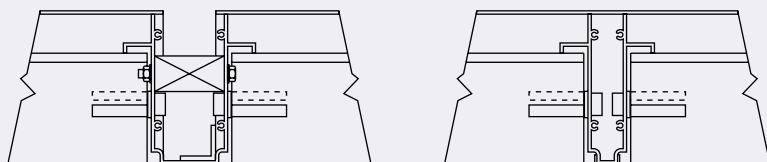

Actuation options

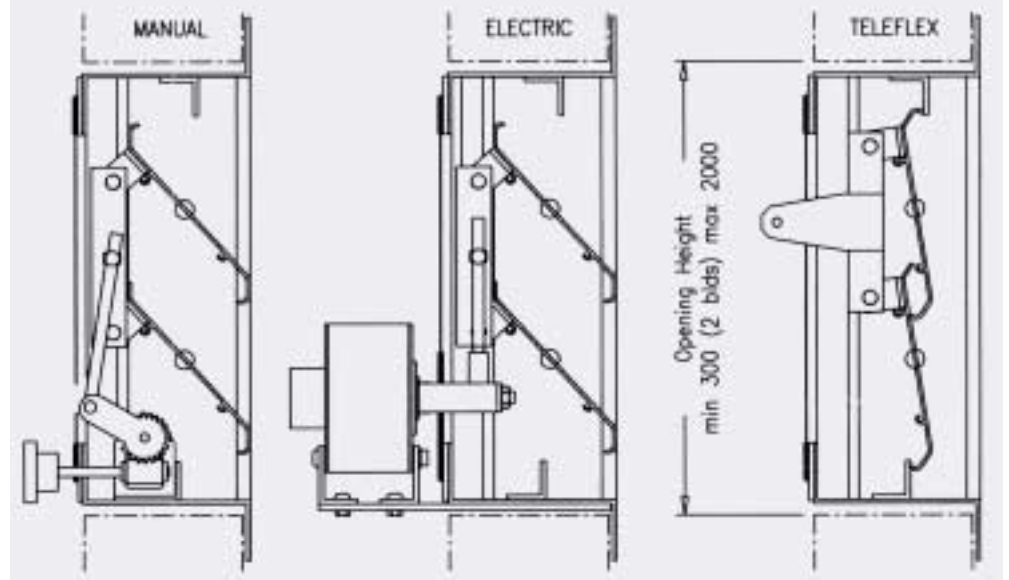

Louvred doors

Single or double opening types available with 50, 75, 100 and SLH-S series blades as standard. Doors are fully louvred and designed to line with adjacent fixed louvre panels when used as an integral part of a louvre installation.

Access panels

Available with either 50, 75 or 100 series blade types. Access panels can be manufactured to suit either builders work openings or to form an integral part of a louvre installation.

Introduction

Specification

Materials

Extruded aluminium grade ENAW 6063T6 to BSEN 755 -1 and -9.

Materials and blades

Extruded aluminium grade ENAW 6063T6 to BSEN 755 -1 and -9.

Blades

Extruded aluminium.
 50 series 1.5mm
 75 series 1.6mm
 100 series 2.0mm

Borders

50, 75, 100A Front flange
 50, 75, 100AC Recessed

Bird wire guard

Fitted as standard.

Bird wire guard

Fitted as standard.

Insect screen

If specified.

Insect screen

If specified.

Gas strut

90° hold open gas strut with support arm, fitted to each opening leaf.

Locks and fixings

To individual requirements – usually bolts and retaining bushes.

Handing

Single door (o/in or o/out)
 RH from outside. Double door (o/in or o/out). Operating leaf RH from outside.

Maximum size

900w x 1200h.

Locks

Guardian sashlock c/w euro cylinder and satin anodised straight lever handles. Slave leaf of double door fitted with flush aluminium shoot bolts head and cill.

Handing

Doors are supplied as single or double leaf units (hinged doors).

Standard maximum sizes

Single door 900w x 2100h.
 Double door 1800w x 2100h.

Pivot doors are also available.

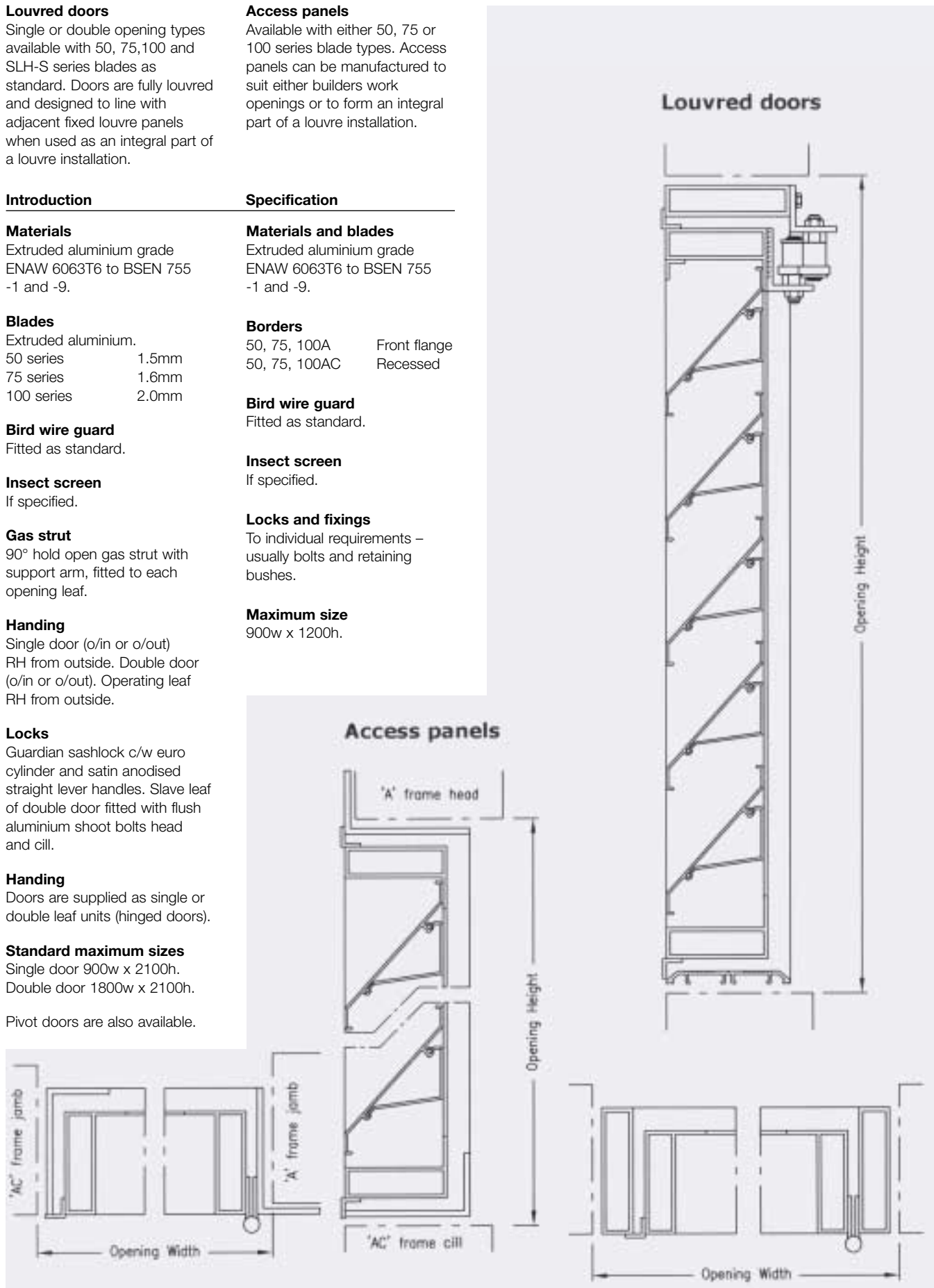

Single door

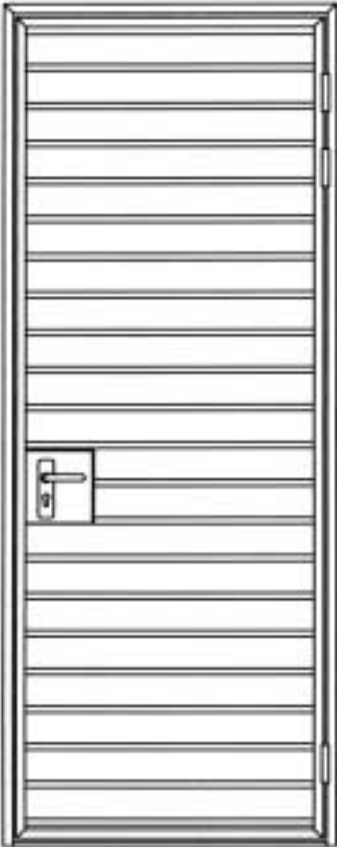

Double door

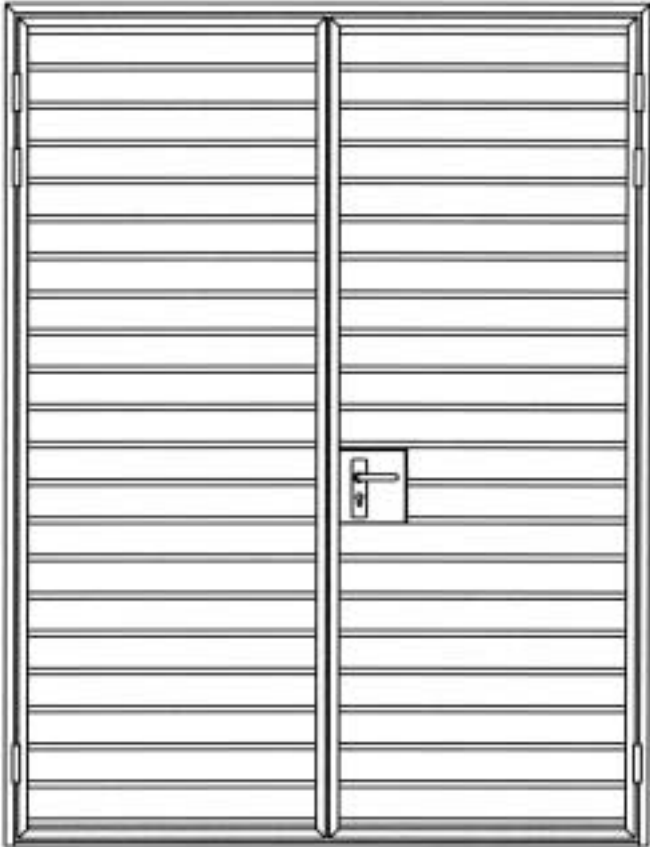

Access panels type 'A' shown

Single access panel



Double access panel



PH series Penthouse louvres



Fixed blade external penthouse louvres with a choice of 50, 75 or 100 series blades. Sheet metal roof and rigid angle frame. Louvres are designed for applications where roof inlet and exhaust terminals are required whilst maintaining the characteristics of sidewall louvres when mounted on a flat roof.

Specification

Materials

Extruded aluminium grade ENAW 6063T6 to BSEN 755 -1 and -9.

Blades & mullions

PH50 as 50 series
PH75 as 75 series
PH100 as 100 series

Roofs

2.5mm aluminium sheet on aluminium angle rafters at 800mm centres.

Bird wire guard

Fitted as standard.

Insect screen

If specified.

Corners

Standard or mitred depending on size.

Specials

The dimensions given opposite apply to standard PH50, PH75 and PH100 penthouse louvres only. Special kerb flange sizes available to suit particular applications please refer to our technical department for details.

Sizes

Specify the inside length and width dimensions of the builders work or timber roof upstand, together with the required height of the penthouse louvre as measured from top of upstand to base of penthouse roof. The penthouse will be manufactured to the nearest full blade size above if required dimension does not utilise exact blade centres. Specify penthouse roof type if not standard pitch as illustrated.

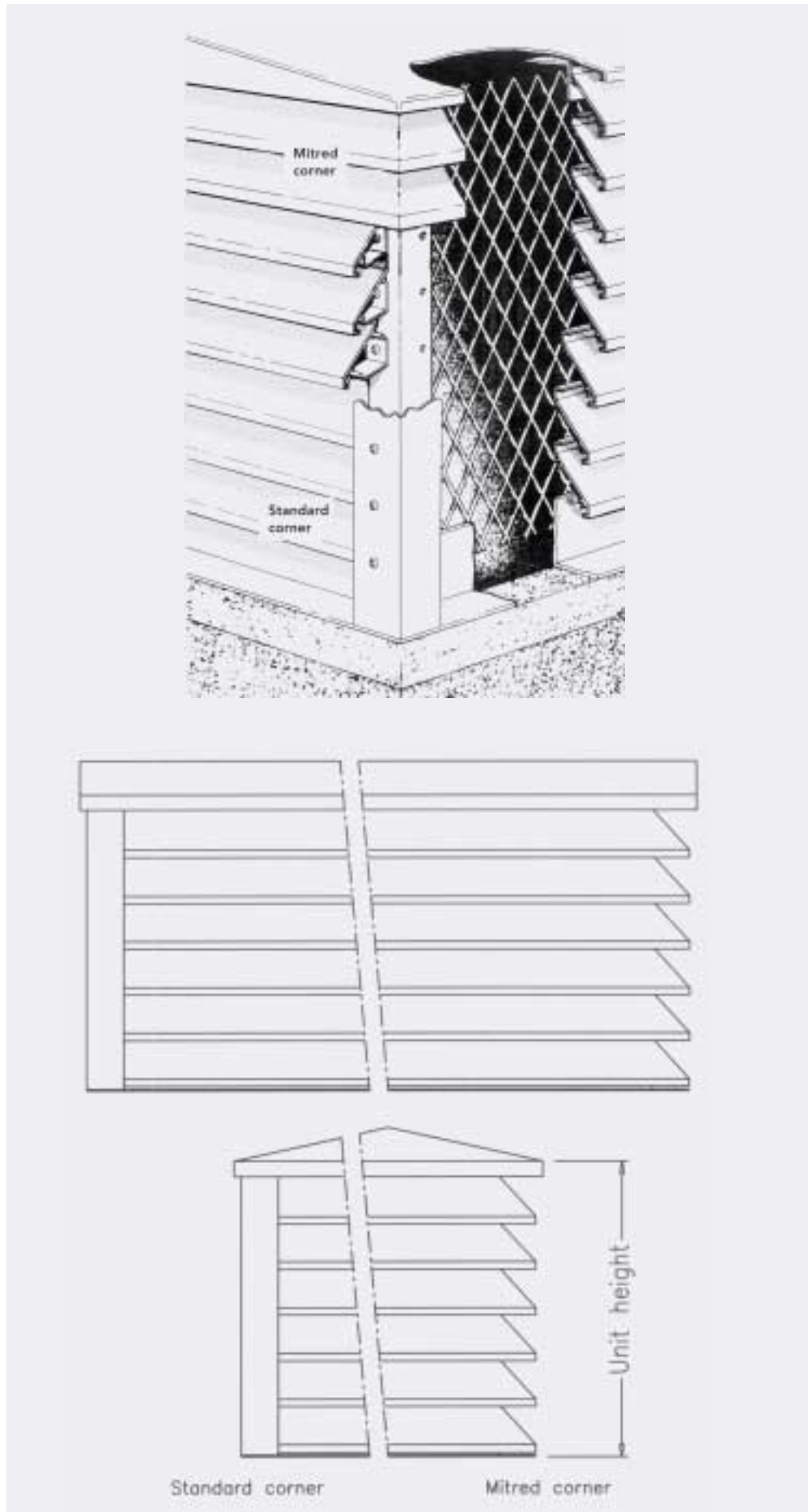

PH series Penthouse louvres



Type PH50

Dim	Description	Size mm
a	Kerb flange width	60
b	Kerb flange height	25
c	Flange thickness	2.25

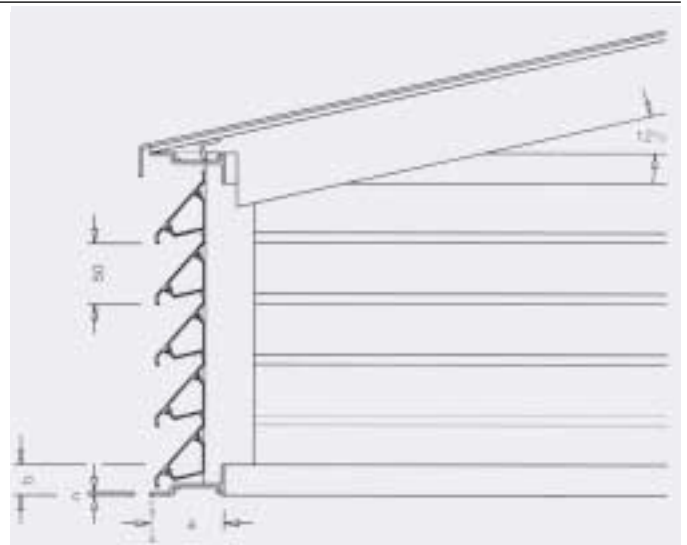

Type PH75

Dim	Description	Size mm
a	Kerb flange width	80
b	Kerb flange height	25
c	Flange thickness	2.5

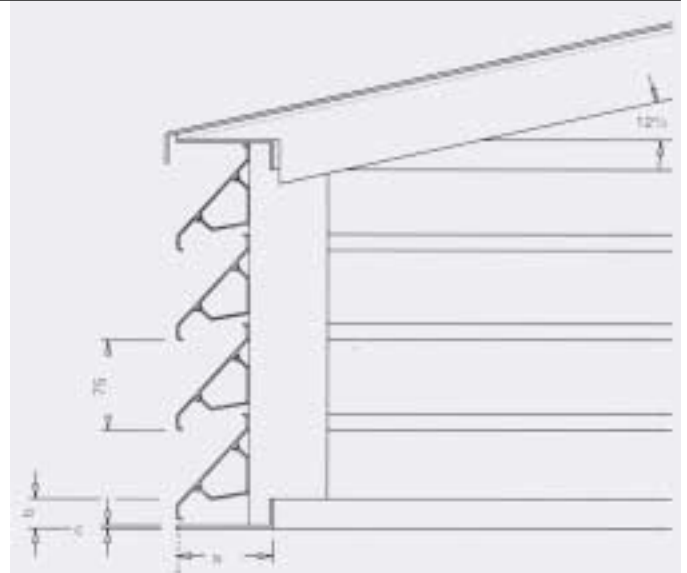

Type PH100

Dim	Description	Size mm
a	Kerb flange width	110
b	Kerb flange height	40
c	Flange thickness	2.5

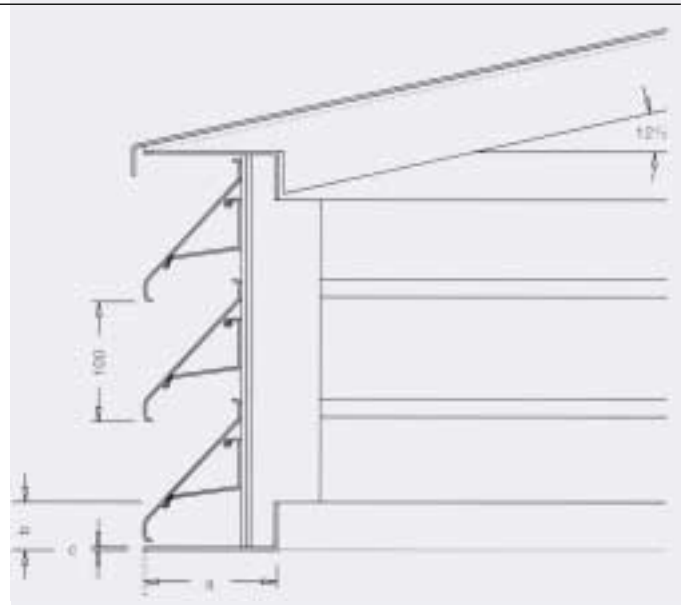

Size requirements

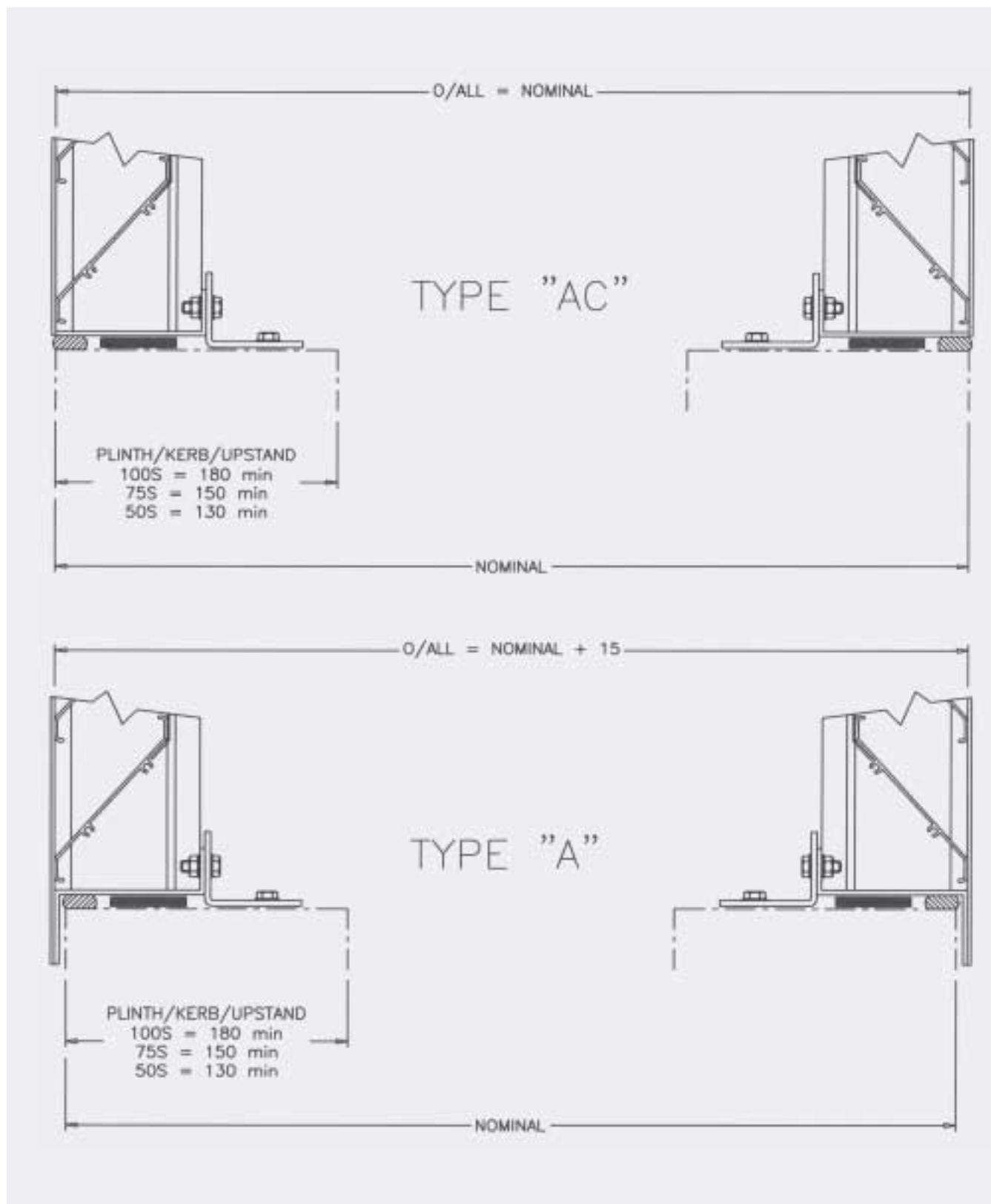

75 Polycarbonate blade louvre



Fixed clear external louvres with 75 mm blade spacing. Suitable for louvre assemblies where a combination of ventilation and natural lighting is needed. Continuous line standard.

Specification

Materials - frame

Extruded aluminium grade ENAW 6063T6 to BSEN 755 -1 and -9.

Blades

5 mm polycarbonate clear (Makrolon 293) UV stabilised. Blades fitted with aluminium extrusion profile at frame and mullion joints for securing to frame / mullion bars.

Finishes - frame

Extruded Aluminium (Mill finish)
Polyester powder - coated to BS6496
Anodised to BS3987.

Bird wire guard

Fitted as standard, 18g expanded aluminium.

Free area

The face core provides approximately 47% free area.

Stiffener bars

Rear mounted stiffener bars are fitted as standard to all louvres over 750 mm in width.

Stiffener bars do not interrupt the external continuous line appearance of louvre blades. Louvre blades are secured to stiffener bars via aluminium support clips.

Mullions

Units manufactured in two or more panels have reverse concealed mullions which project 45mm beyond the rear of the frame.

Frame types

A or AC frames are available (and may be combined if required, eg. A head, AC cill) together with AC channel frame for glazing applications glazing thickness 25mm.

Note

Head and cill blades are in aluminium. Where height dimension is not completely divisible by blade centres, the head blade will comprise a formed section.

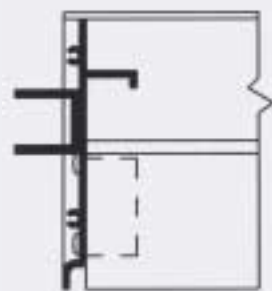
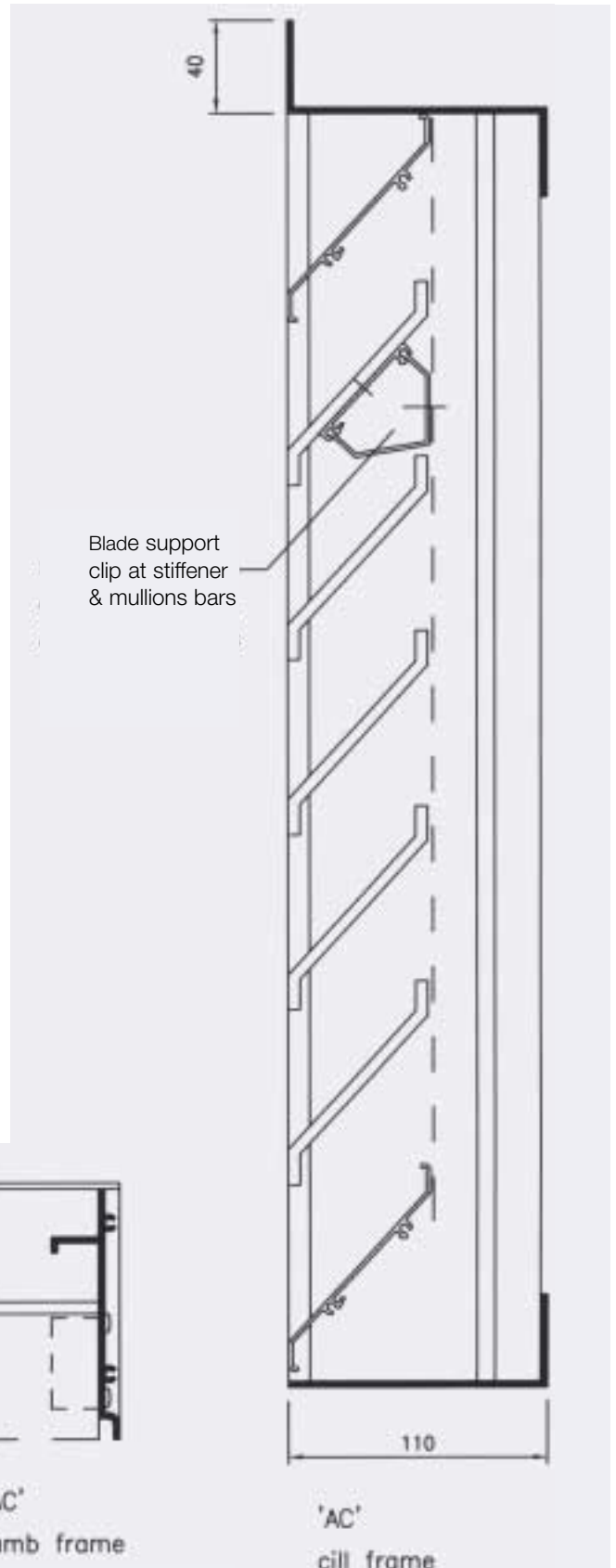

'AC' channel
Jamb frame



'A'
jamb frame

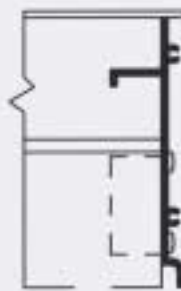

'AC'
jamb frame

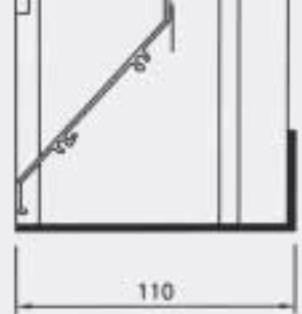

'AC'
cill frame

Slimtype Aluminium Louvre



Specification

Materials

Extruded aluminium grade
ENAW 6063T6 to BSEN 755
-1 and -9.

Frame construction

Channel frame 25 x 25 x 1.6mm
Blade general thickness 1.5mm.

Blades screw fixed to jamb
channels.

Head and cill frame fixed with
pop rivet to top / bottom
louvre blade.

Finishes

Extruded aluminium (mill finish).

Polyester powder coated to
BS 6496.

Anodised to BS3987.

Bird wire guard

If specified, 18g expanded
aluminium.

Insect mesh

If specified, 23g expanded
aluminium.

Blanking plates

If specified - 18g aluminium.

Brace bars

Fitted on units over 800 mm
wide.

Free area

The face core area provides
approximately 40% free area.

Drain system

Any water droplets which may
collect in the cill profile will be
drained at the jambs into the
glazing system.

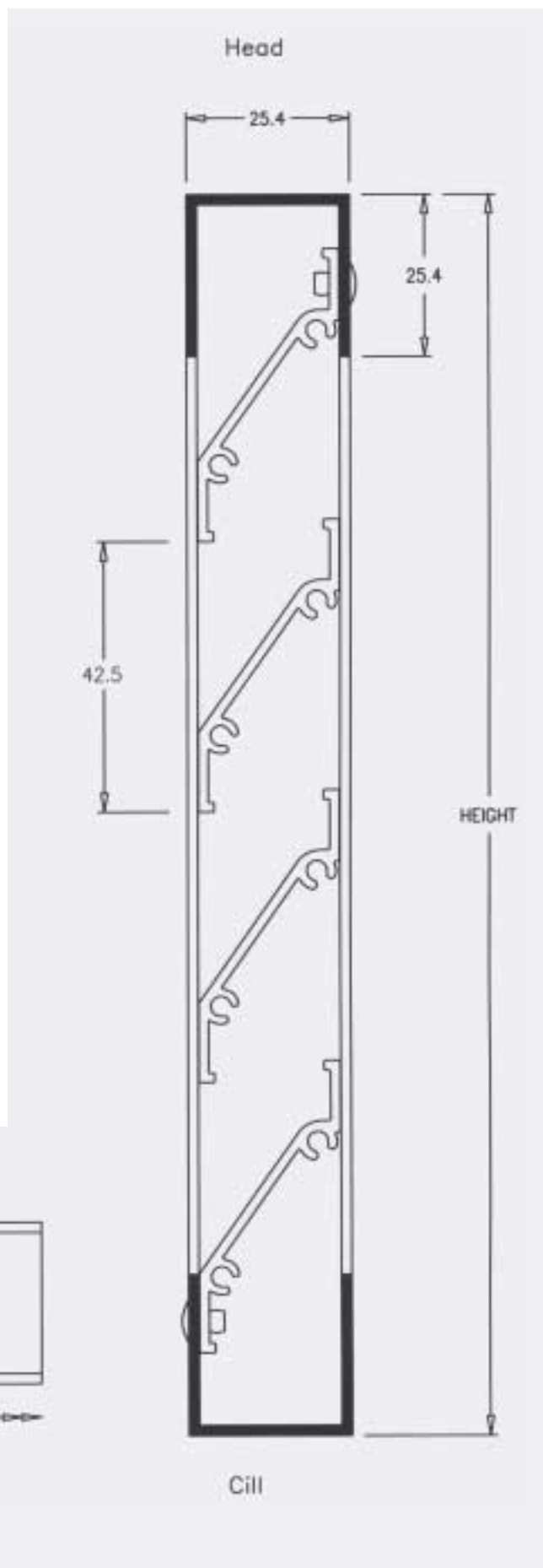

Trickle Louvre



Designed to fit into window or curtain wall systems, Trickle louvres provide a pleasing visual option while limiting the passage of air. Typical use is in stair or refuge areas of buildings where ventilation is required but strong winds entering the area are not desirable.

Specification

Materials

Extruded aluminium grade
ENAW 6063T6 to BSEN 755
-1 and -9.

Frame construction

Channel frame 25 x 25 x 1.6mm
Blade general thickness 1.6mm.

Blades screw fixed to jamb channels.

Head and cill frame fixed with pop rivet to top / bottom louvre blade.

Finishes

Extruded aluminium (mill finish).

Polyester powder coated to BS 6496.

Anodised to BS3987.

Bird wire guard

Not required.

Drain system

Any water droplets which may collect in the cill profile will be drained at the jambs into the glazing system.

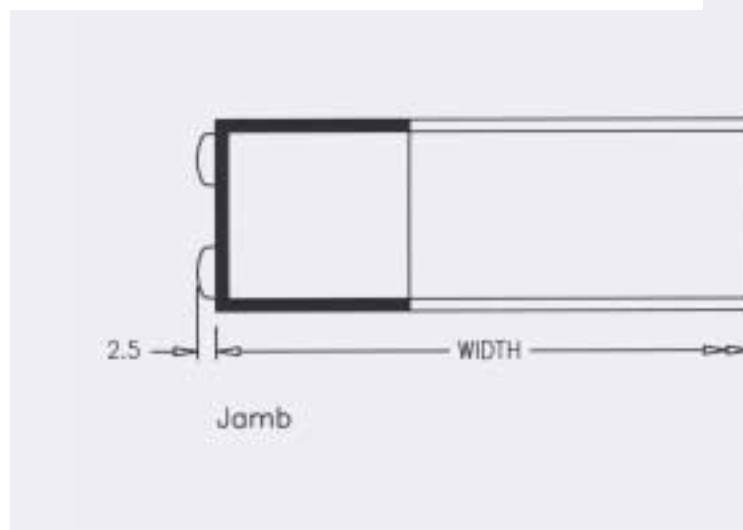
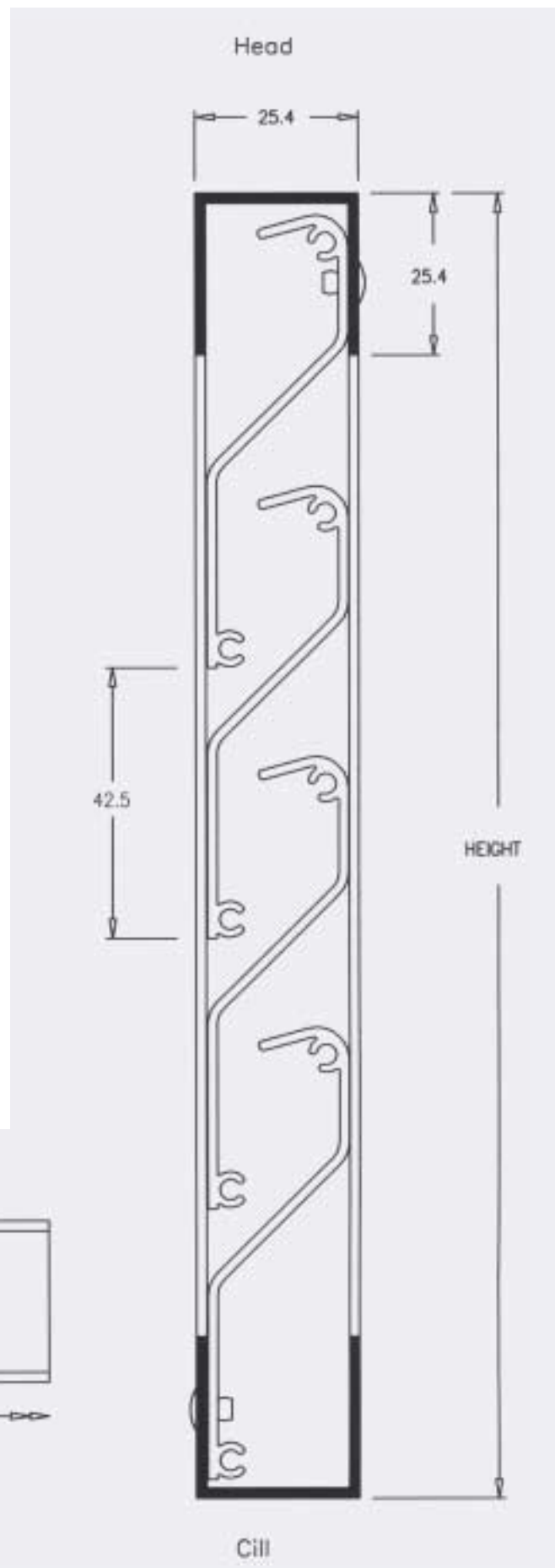



ST series Sandtrap louvres



Designed to remove the bulk of airborne sand and dust from inlet air in dry, dusty or sandy climates whilst maintaining reasonable air flowrate characteristics by means of a special double blade design.

ST series sandtrap louvres are capable of performing as natural ventilators or to alleviate the load on the main filtration stages of air conditioning equipment.

Sand and dust is evacuated from the base of the louvre by means of a special sand collection/dispersion cill, keeping maintenance to a minimum and ensuring the design air flowrate under all conditions.

Specification

Materials and construction

Aluminium press-formed in 16g or 14g depending on size.

Finish

Polyester powder coating or mill finish.
(Anodising not recommended).

Screen

Supplied without screen as standard.

Insect screen (IS) or birdwire guard (BWG) available as an option.

Sizes available

Available in width and height increments of 100mm up to a maximum single panel size of 1500 W x 1500 H.

For larger sizes please contact our Sales Office.

Notes to performance data

a) Pressure loss data based on atmosphere to duct readings [inletmode].

b) Velocities given are face velocities; for jet velocities, multiply face velocity x 3.

c) Data given based on performance without insect screen.

The pressure loss table indicates pressure drops against inlet velocities up to a maximum of 3.0 m/s. In practice, velocities above 2.0m/s are usually undesirable in dusty/sandy atmospheres as the ability of the louvre to remove airborne particles decreases to unacceptable levels above this velocity. Efficiency of approximately 40 – 60% can be expected at velocities of 1.5m/s, dependent on sand/dust particle size.

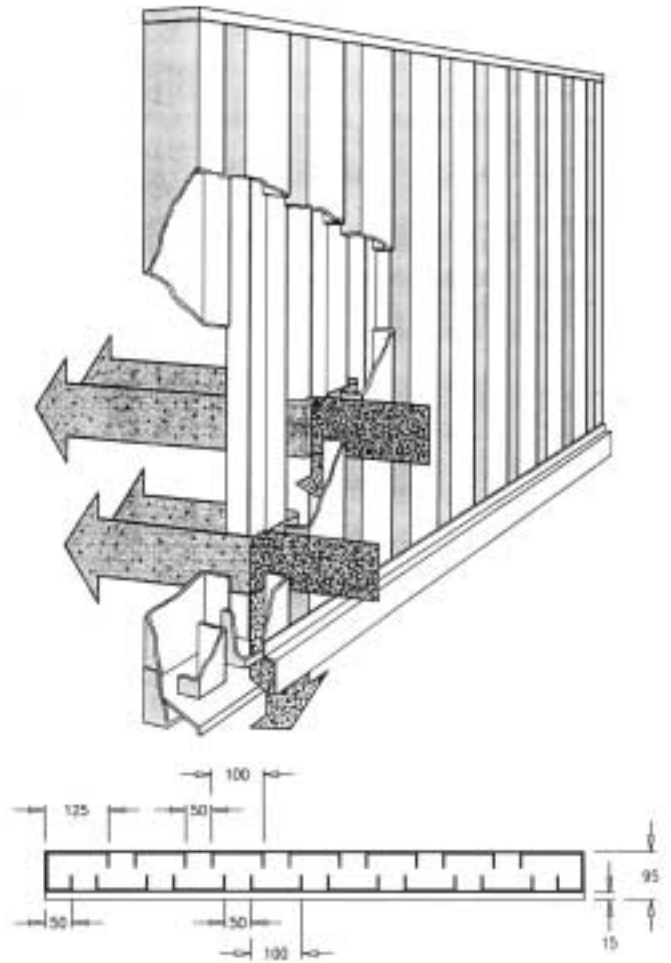

Performance data

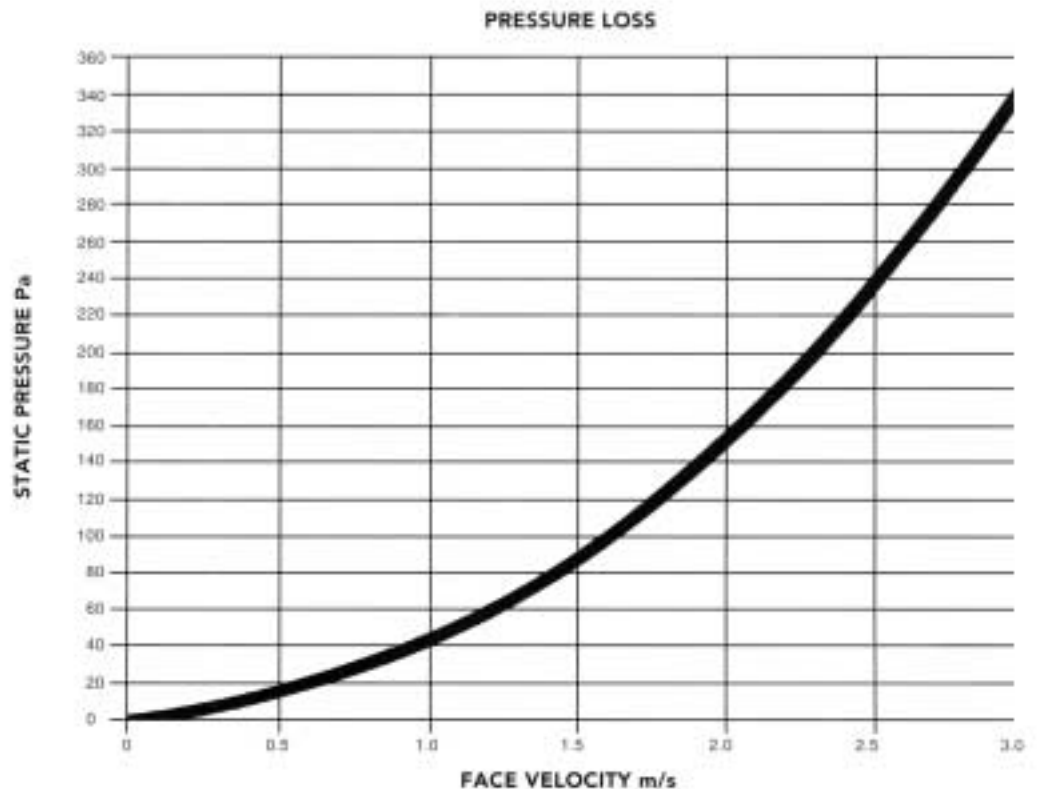

Typical details for horizontal and vertical couplings, similar for all louvre types

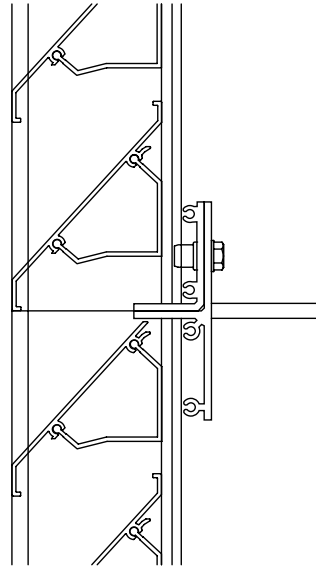
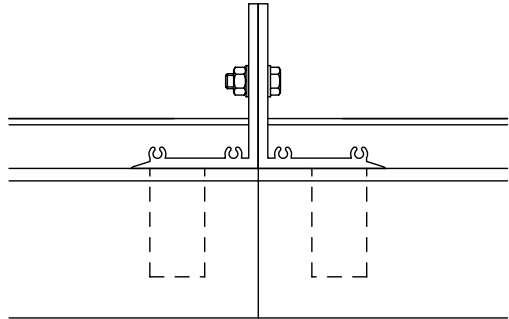

Fitting detail into curtain walling / PVCu

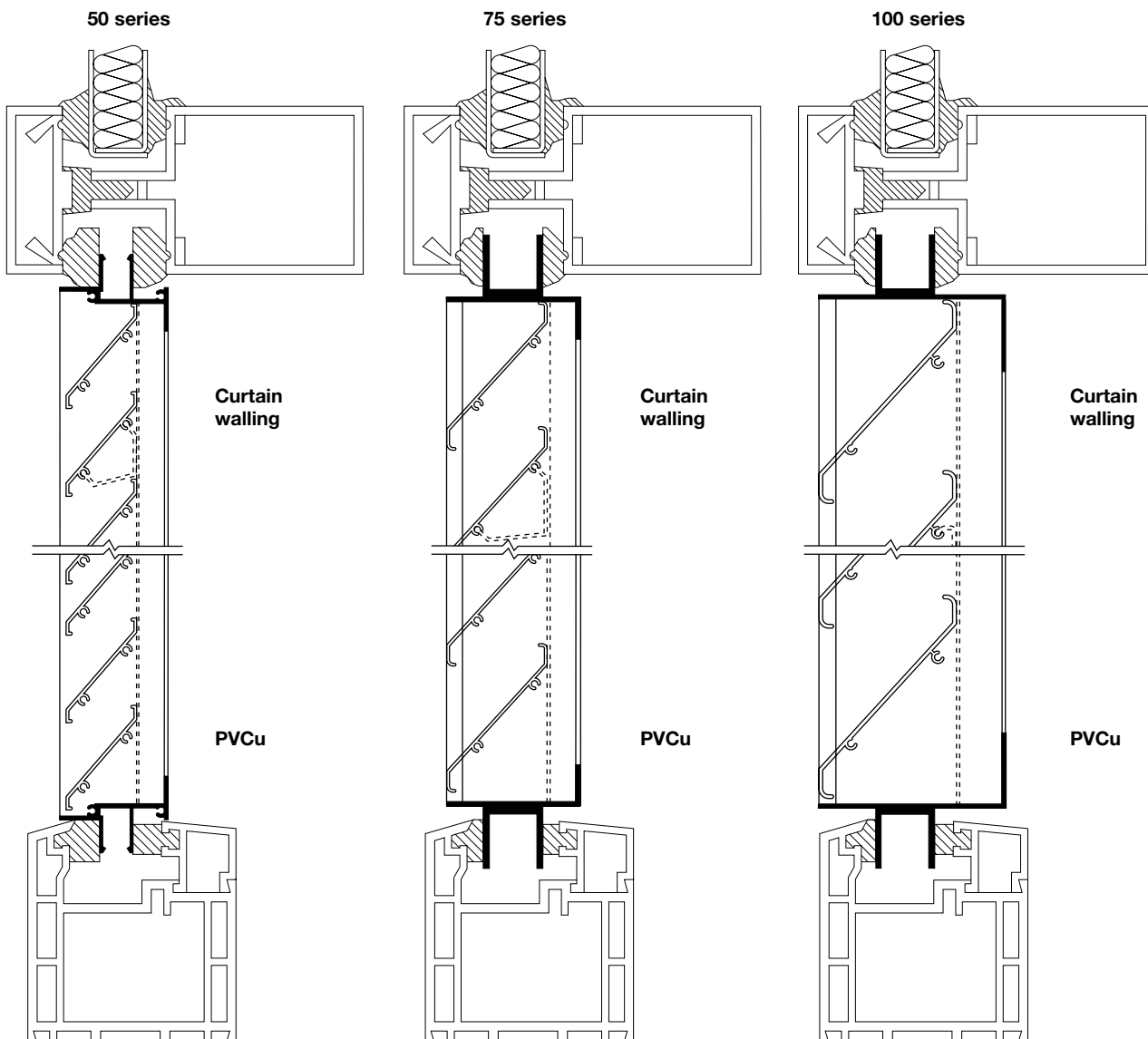

A series

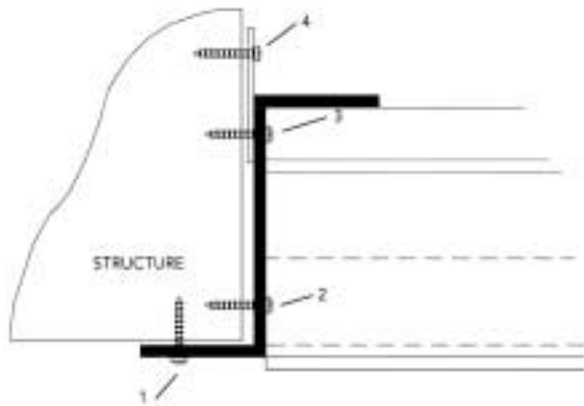

- 1. Fixing through front flange.
- 2. Fix through jamb frame 'front' between blade centres.
- 3. Fix through jamb frame 'rear'.
- 4. Flat bar lug fixing.

AC series

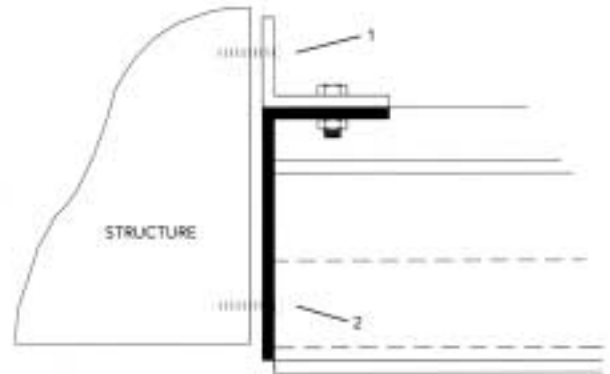

- 1. Fixing from rear via angle bracket. Special formed fixing brackets can be produced to accommodate almost any condition.
- 2. Fix through jamb frame 'front' between blade centres.

Louvre support & alignment clip application

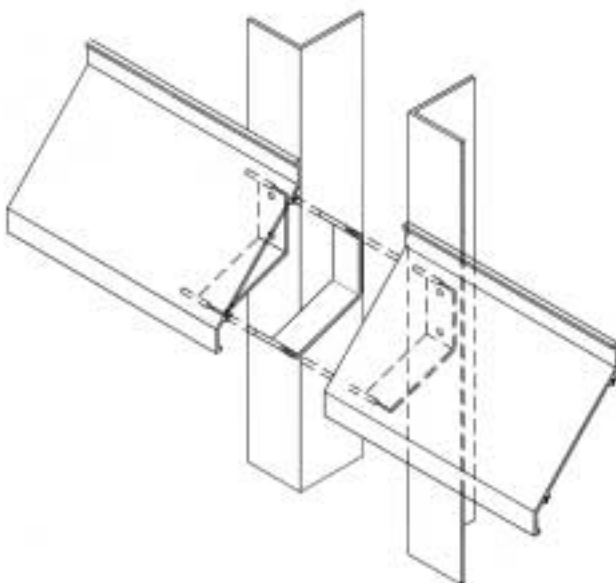

Coupling detail continuous line louvres

Fixing off coupling mullion to intermediate steel work where required.

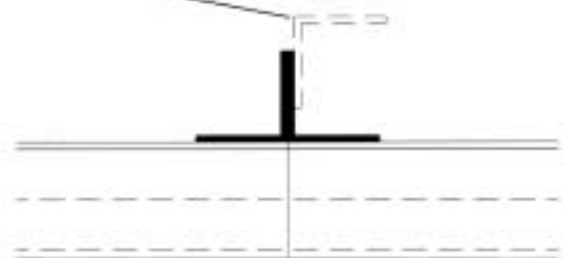

Note - Sections shown are diagrammatic and apply to all louvre types.

Product range:

Metal Louvres

Acoustic Louvres

Glass Louvres

Sunscreens

Ellipsoid Sunbreakers

We offer supply only or supply and fix
for the UK market.

For export we generally offer supply,
on FOB or CIF basis.

Installation

It is very important from both the practical and visual aspects to ensure that installation of a louvre / screen scheme is carried out professionally and we do offer a full installation service for our products

With the high commitment we offer towards managing our projects and health and safety considerations, we are able to work in all site environments and undertake risk assessments and method statements as a standard part of our working practice.

Drawing / Site Survey

Working drawings are prepared where necessary for client's approval prior to

commencement of manufacture. For smaller projects standard details will be issued showing louvre details and size points.

For those projects where full client's details are not available, we will undertake a site survey prior to preparation of drawings and manufacture.

Supply only

For smaller projects where we are required to supply only, surround frames will normally be supplied undrilled for site drilling during installation. However, where powder coat finishes are required, we recommend factory pre-drilling to customer supplied details.



Ruskin Air Management Limited
a BS EN ISO 9000 registered company

The statements made in this brochure or by our representatives in consequence of any enquiries arising out of this document are given for information purposes only. They are not intended to have any legal effect and the company is not to be regarded as bound thereby. The company will only accept obligations which are expressly negotiated for and agreed and incorporated into a written agreement made with its customers.

Due to a policy of continuous product development the specification and details contained herein are subject to alteration without prior notice.

Stourbridge Road
Bridgnorth
Shropshire WV15 5BB

Telephone 01746 761921
Facsimile 01746 766450

Website www.naco.co.uk
E-mail sales@naco.co.uk



© Ruskin Air Management Limited
LS 9928 (05.06)